

Honeywell

Voyager GS™ 9590 Series

Single-Line Hand Held Laser Scanner

User's Guide

Disclaimer

Honeywell International Inc. (“HII”) reserves the right to make changes in specifications and other information contained in this document without prior notice, and the reader should in all cases consult HII to determine whether any such changes have been made. The information in this publication does not represent a commitment on the part of HII.

HII shall not be liable for technical or editorial errors or omissions contained herein: nor for incidental or consequential damages resulting from the furnishing, performance, or use of this manual.

This document contains propriety information that is protected by copyright. All rights reserved. No part of this document may be photocopied, reproduced, or translated into another language without the prior written consent of HII.

© 2007 - 2011 Honeywell International Inc. All rights reserved.

Web Address: www.honeywellaidc.com

Trademarks

MetroSelect, MetroSet2, Metrologic, and Solaris are trademarks or registered trademarks of Metrologic Instruments, Inc. or Honeywell International Inc.

Microsoft, Windows 95, and Windows are registered trademarks of Microsoft Corporation.

IBM is a trademark of International Business Machines Corporation.

Checkpoint is a registered trademark of Checkpoint Systems, Inc.

Other product names mentioned in this manual may be trademarks or registered trademarks of their respective companies and are the property of their respective owners.

Patents

For patent information, please refer to www.honeywellaidc.com/patents.

TABLE OF CONTENTS

Introduction

Product Overview	1
Scanner and Accessories.....	2
Scanner Components.....	4
Cable Installation and Removal.....	5
Labels.....	6

Scanner Installation

RS232 (-14).....	7
RS485 (-106).....	8
Keyboard Wedge (-47).....	9
Stand-Alone Keyboard (-47).....	10
USB (-38 and -106).....	11
Additional Settings for EAS Equipped Models.....	12

Stands

Flex Stand (PN 46-00709)	
Components.....	13
Assembly.....	14
Optional Fixed Mount	15
Optional Wall/Tabletop Stand (PN 46-00885)	
Optional Fixed Mount	16

Scanner Operation

Default Modes of Operation.....	17
Scanning with the Manual Activation Mode.....	17
Maintenance.....	17

Indicators

Audible	18
Visual.....	19
Failure Modes.....	20

TABLE OF CONTENTS

Configuration Modes	21
Upgrading the Flash ROM Firmware	22
Depth of Field	
MS9590	23
MS9591	24
IR Activation Range	
MS9590	25
MS9591	25
Applications and Protocols	26
Troubleshooting Guide	27
Design Specifications	
Operational.....	30
Mechanical	31
Electrical.....	31
Environmental	31
Scanner and Cable Terminations	
Scanner Pinout Connections	32
Cable Connector Configurations	33
Limited Warranty	35
Regulatory Compliance	
Safety	36
EMC	37
Index.....	40
Customer Support	42

INTRODUCTION

Product Overview

The VoyagerGS™ 9590 series is part of Honeywell's extensive Voyager™ branded hand-held laser scanning product family. The VoyagerGS series is the first Voyager product to feature trigger scanning in its design. The VoyagerGS provides an aggressive solution for scanning all standard 1D bar codes in a new ergonomic form factor that maximizes comfort and reduces fatigue.

Key product features include:

- Rapid scan speed of 100 scans per second
- Extended depth of field
- CodeGate® data transmission technology
- Manual-trigger operation and automatic in-stand detection
- Data formatting
- Easy configuration with MetroSelect® bar codes and MetroSet® 2 Windows® compatible software
- Optional integration of Checkpoint EAS deactivation antenna
- Optional high-density model, MS9591

MODEL	INTERFACE
MS9590 – 14	RS232 - TXD, RXD, RTS, CTS, DTR, DSR
MS9590 – 47	Keyboard Wedge, Stand-Alone Keyboard and RS232 Transmit/Receive
MS9590 – 106	RS485 [◇] , USB** and RS232 Transmit/Receive
High Density Models	
MS9591– 14	RS232 - TXD, RXD, RTS, CTS, DTR, DSR
MS9591 – 47	Keyboard Wedge, Stand-Alone Keyboard and RS232 Transmit/Receive
MS9591 – 106	RS485 [◇] , USB** and RS232 Transmit/Receive
EAS Equipped Models	
MS9590-38-EAS	USB* and RS232 Transmit/Receive with EAS
MS9590-40-EAS	USB, IBM OEM with EAS
* Scanner model is configurable for Keyboard Emulation Mode or Bi-Directional USB Serial Emulation Mode. The default setting is Keyboard Emulation Mode.	
** Scanner model is configurable for Keyboard Emulation Mode, Bi-Directional USB Serial Emulation Mode, or IBM OEM. The default setting is Keyboard Emulation Mode.	
◇ Applicable for IBM® host applications	

INTRODUCTION

Scanner and Accessories

BASIC KIT	
Part #	Description
MS9590 or MS9591	MS9590 Bar Code Scanner or MS9591 High-Density Bar Code Scanner
00-02544	MetroSelect Single-Line Configuration Guide♦♦
00-05150	VoyagerGS 9590 Series User's Guide♦♦
♦♦ Available for download at www.honeywellaidc.com .	

OPTIONAL ACCESSORIES	
Part #	Description
46-00709	Flex Stand
46-00885	Wall Mount
AC to DC Power Transformer- Regulated 5.2VDC @ 1A output.	
46-00525	90VAC to 255VAC, United States, Canada and Japan
46-00526	90VAC to 255VAC, Continental European
46-00870	90VAC to 255VAC, United Kingdom
46-00528	90VAC to 255VAC, Australia
46-00529	90VAC to 255VAC, China

Other items may be ordered for the specific protocol being used. To order additional items, contact the dealer, distributor, or call the customer service department. See page 42 for contact information.

Scanner and Accessories

OPTIONAL ACCESSORIES	
Part #	Description
	<p>Cable Compatibility Warning</p> <p>Use only MS9590 series compatible product cables from the list below. Damage may occur to the scanner if incompatible cables are used. Any damage incurred from incorrect cable usage will void the limited warranty shown on page 35.</p>
53-53000.x-3	RS232 PowerLink Cable with Built in Power Jack Black <i>Coiled</i> Cord with Long Strain Relief
53-53802.x-N-3	Keyboard Wedge Cable with Adapter Cable Black <i>Coiled</i> Cord with Long Strain Relief
53-53820.x-N-3	Stand-Alone Keyboard Cable Black <i>Coiled</i> Cord with Long Strain Relief
53-53813.x-N-3	USB Cable, Locking Plus-Power™ Type A Black <i>Coiled</i> Cord with Long Strain Relief
53-53809.x-N-3	USB Cable, Type A Black <i>Coiled</i> Cord with Long Strain Relief
MVC**	Voltage Converter Cable ±12VDC to +5.2VDC for RS485 [◇] Applications
<p>** Contact a customer service representative for additional information on the MVC converter cable series and the host connections available.</p> <p>◇ Applicable for IBM[®] host applications</p>	
The following cables are only for MS9590 models equipped with EAS.	
55-55809.x-N-E-3	USB Cable, Type A, with <i>EAS Connection Wire</i> Black <i>Straight</i> Cord with Long Strain Relief
55-55800.x-E-3	RS232 PowerLink Cable with Built in Power Jack and <i>EAS Connection Wire</i> Black <i>Straight</i> Cord with Long Strain Relief

Other items may be ordered for the specific protocol being used. To order additional items, contact the dealer, distributor, or call customer service department. See page 42 for contact information.

Scanner Components

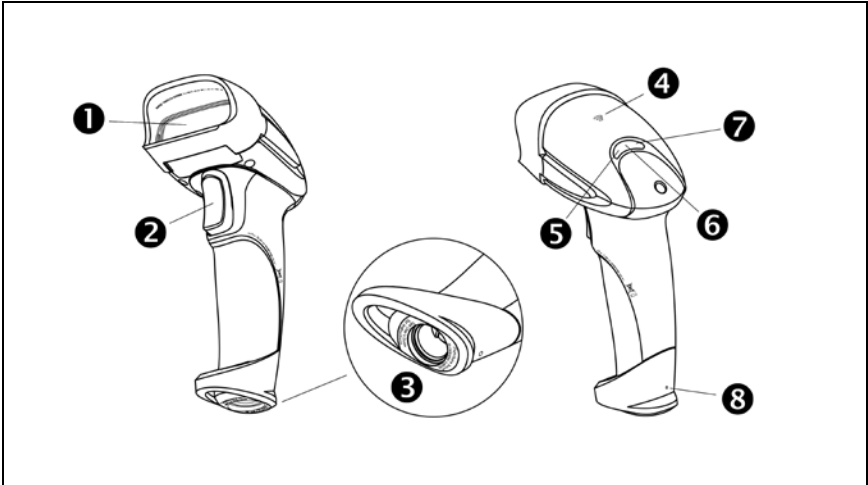

No.	Item Description	
1	Window	Laser Aperture
2	Trigger	See <i>How to use CodeGate</i> on page 17
3	Cable Connection	10-pin RJ45, Female Socket, See <i>Scanner Pinout Connections</i> on page 32
4	Speaker	See <i>Audible Indicators</i> on page 18
5	White LED	See <i>Visual Indicators</i> on page 19
6	Blue LED	See <i>Visual Indicators</i> on page 19
7	Yellow LED	See <i>Visual Indicators</i> on page 19
8	Cable Release Pin-Hole	See <i>The PowerLink Cable</i> on page 5

Figure 1. Scanner Components

Cable Installation and Removal

Installation

i Important: If the cable is not fully latched, the unit can power intermittently.

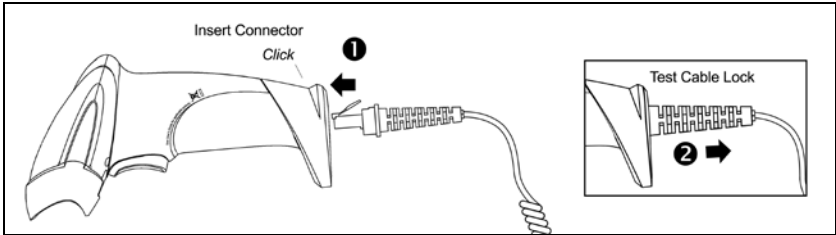

Figure 2. Connecting the Cable

1. Plug the 10-pin RJ45 end of the cable into the 10-pin socket on the scanner. There will be an audible *click* when the connector lock engages.
2. Gently pull on the cable strain relief to insure the cable is securely installed.

Removal

Before removing the cable from the scanner, Honeywell recommends that power to the host system be turned off. If the cable is a PowerLink cable, disconnect the power supply on the cable.

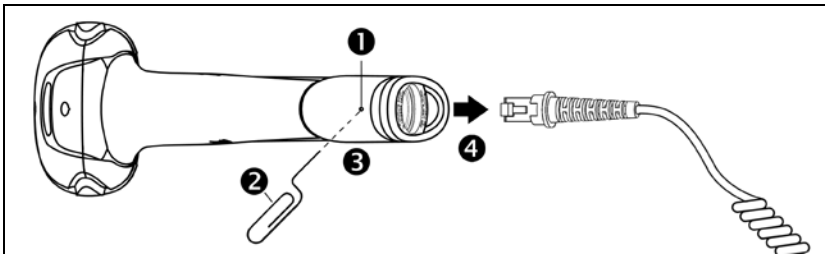

Figure 3. Releasing the Cable

1. Locate the small *dimple* on the handle of the unit near the cable connection.
2. Bend an ordinary paperclip into the shape shown above in *Figure 3*.
3. To release the cable lock, push the end of the paperclip through the rubber on the handle where the *dimple is located*.
4. There will be an audible *click* when the connector lock releases. Pull gently on the strain-relief of the cable to separate the cable from the scanner.

INTRODUCTION

Labels

Every MS9590 and MS9591 has a serial number label located on the underside of the scanner head and molded text on the scanner handle. The label and molded text provide important information such as the unit's date of manufacture, serial number, CE and caution information. See Figure 4 for examples of these items and their location on the scanner.

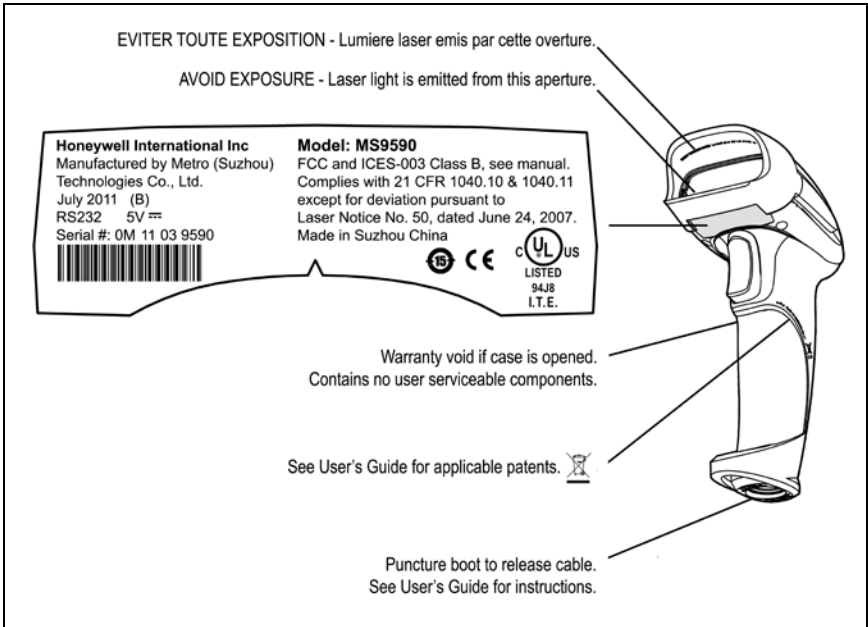

Figure 4. Molded Text and Serial Number Label



Caution:

To maintain compliance with applicable standards, all circuits connected to the scanner must meet the requirements for SELV (Safety Extra Low Voltage) according to EN/IEC 60950-1.

To maintain compliance with standard CSA-C22.2 No. 60950-1/UL 60950-1 and norm EN/IEC 60950-1, the power source should meet applicable performance requirements for a limited power source.

SCANNER INSTALLATION

RS232 (-14)

1. Turn off the host device.
2. Plug the 10-pin RJ45 end of the PowerLink cable into the 10-pin socket on the scanner. There will be an audible *click* when the connector lock engages.
3. Connect the 9-pin D-type connector of the PowerLink cable to the proper COM port on the host device.

If the scanner is receiving power from the host system, skip to step #6.

4. Plug the power supply into the power jack on the PowerLink cable.



Check the AC in input requirements of the power supply to verify the voltage matches the AC outlet. The outlet must be located near the equipment and be easily accessible.

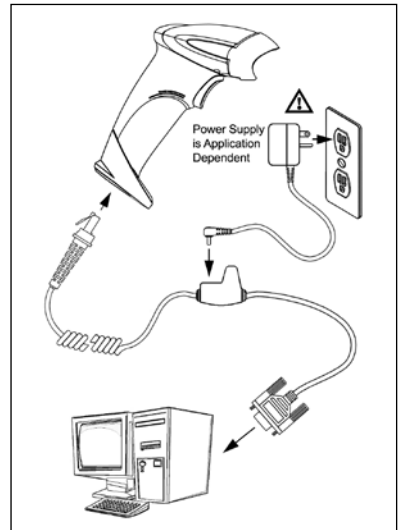

Figure 5.

5. Connect AC power to the transformer.
6. Turn on the host device.



The scanner is shipped from the factory configured to set of default conditions. Plugging the scanner into a port on the host system does not guarantee that the scanned information will be communicated properly to the host device. The scanner and host device *must* use the same communication protocol. Please refer to the MetroSelect Single-Line Configuration Guide or the help files provided with MetroSet2 for instructions on changing the scanner's factory default configuration.



See caution on page 6.

SCANNER INSTALLATION

RS485[◇] (-106)

1. Turn off the host device.
2. Plug the 10-pin RJ45 end of the MVC cable into the 10-pin socket on the scanner. There will be an audible *click* when the connector lock engages.
3. Connect the other end[◇] of the MVC cable to the host device.
4. Turn on the host device.
5. The blue LED on the scanner will turn on, the white LED will flash, and the scanner will beep once.
6. Scan the bar code below to activate the RS485 interface.

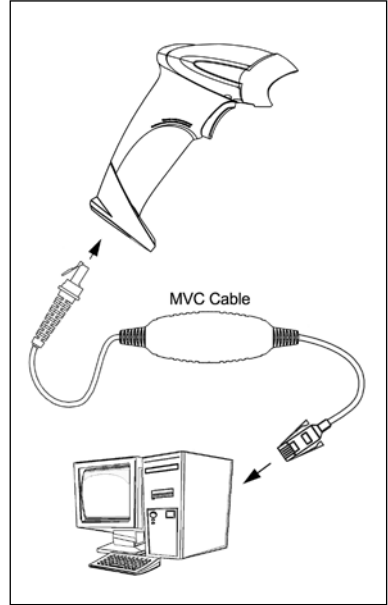

Figure 6.



USB is the default communication protocol for an MS9590-106 and the MS9591-106. If the *recall defaults* bar code is scanned after the unit has been configured for RS485, the scanner will revert to the USB default communication protocol. The bar code above will need to be rescanned to return the unit to the RS485 communication protocol.



The scanner is shipped from the factory configured to set of default conditions. Plugging the scanner into a port on the host system does not guarantee that the scanned information will be communicated properly to the host device. The scanner and host device *must* use the same communication protocol. Please refer to the MetroSelect Single-Line Configuration Guide or the help files provided with MetroSet2 for instructions on changing the scanner's factory default configuration.



See caution on page 6.

- ◇ Applicable for IBM[®] host applications
- ◆ The type of host connection available on an MVC cable is application dependent. Contact a customer service representative for additional information on the MVC converter cable series. See page 42 for contact information.

SCANNER INSTALLATION

Keyboard Wedge (-47)

1. Turn off the host device.
2. Plug the 10-pin RJ45 end of the cable into the 10-pin socket on the scanner. There will be an audible *click* when the connector lock engages.
3. Disconnect the host device's keyboard.
4. Connect the "Y" ends of the cable to the keyboard and keyboard port on the host device. If necessary, use the male/female adapter cable supplied with the scanner cable to make the proper connections.

If the scanner is receiving power from the host system, skip to step #7.

5. Plug the power supply into the power jack on the PowerLink cable.



Check the AC in input requirements of the power supply to verify the voltage matches the AC outlet. The outlet must be located near the equipment and be easily accessible.

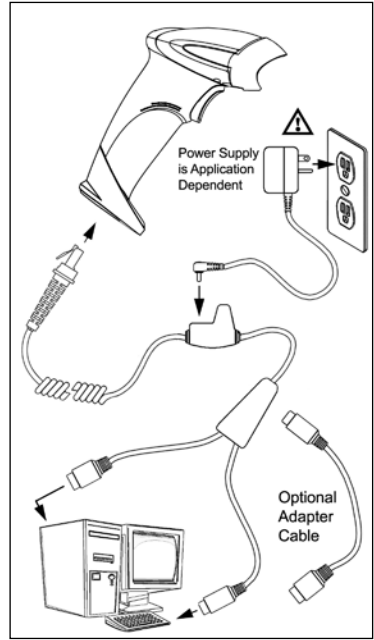

Figure 7.

6. Connect AC power to the transformer.
7. Turn on the host device.



The scanner is shipped from the factory configured to set of default conditions. Plugging the scanner into a port on the host system does not guarantee that the scanned information will be communicated properly to the host device. The scanner and host device *must* use the same communication protocol. Please refer to the MetroSelect Single-Line Configuration Guide or the help files provided with MetroSet2 for instructions on changing the scanner's factory default configuration.

Powering the MS9590-47 or the MS9591-47 directly from the host device may cause interference with the operation of the scanner or the host device. Not all host devices supply the same current through the keyboard port. Contact a customer service representative for information on available external power supplies.



See caution on page 6.

SCANNER INSTALLATION

Stand-Alone Keyboard (-47)

1. Turn off the host system.
2. Plug the 10-pin RJ45 end of the cable into the 10-pin socket on the scanner. There will be an audible *click* when the connector lock engages.
3. Plug the other end of the cable into the host's keyboard port

If the scanner is receiving power from the host system, skip to step #6.

4. Plug the power supply into the power jack on the PowerLink cable.



Check the AC in input requirements of the power supply to verify the voltage matches the AC outlet. The outlet must be located near the equipment and be easily accessible.

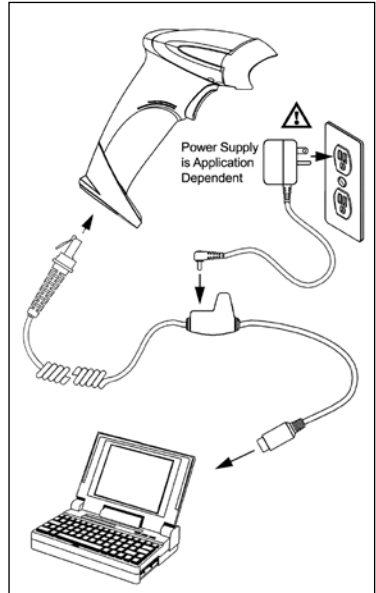

Figure 8.

5. Connect AC power to the transformer.
6. Turn on the host device.



The scanner is shipped from the factory configured to set of default conditions. Plugging the scanner into a port on the host system does not guarantee that the scanned information will be communicated properly to the host device. The scanner and host device *must* use the same communication protocol. Please refer to the MetroSelect Single-Line Configuration Guide or the help files provided with MetroSet2 for instructions on changing the scanner's factory default configuration.

Powering the MS9590-47 or the MS9591-47 directly from the host device may cause interference with the operation of the scanner or the host device. Not all host devices supply the same current through the keyboard port. Contact a customer service representative for information on available external power supplies.



See caution on page 6.

SCANNER INSTALLATION

USB (-106,-38-EAS, and -40-EAS)♦

1. Turn off the host system.
2. Plug the 10-pin RJ45 end of the USB cable into the 10-pin socket on the scanner. There will be an audible *click* when the connector lock engages.
3. Plug the USB Type A end of the cable into the host's USB port.



Cables supplied with MS9590-38-EAS and MS9590-40-EAS models have additional wires for Checkpoint device connections. Refer to page 12 for additional information on Checkpoint device connection.

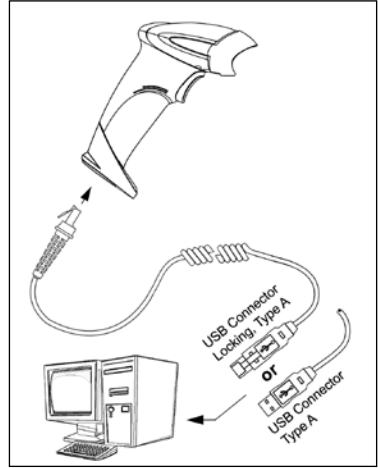

Figure 9.

4. Turn on the host device.



USB is the default communication protocol for the MS9590-106 and the MS9591-106. Both the -38 interface and the -106 interface scanners have *USB Keyboard Emulation Mode* enabled by default when shipped from the factory.

Both the -38 interface and the -106 interface scanners are configurable for *Bi-Directional Serial Emulation mode*. IBM OEM support is only available with the MS9590-106 and the MS9591-106.

Refer to the USB section in the MetroSelect Single-Line Configuration Guide (PN 00-02544) for USB configuration bar codes.



The scanner is shipped from the factory configured to set of default conditions. Plugging the scanner into a port on the host system does not guarantee that the scanned information will be communicated properly to the host device. The scanner and host device *must* use the same communication protocol. Please refer to the MetroSelect Single-Line Configuration Guide or the help files provided with MetroSet2 for instructions on changing the scanner's factory default configuration.



See caution on page 6.

- ♦ The MS9590-38-EAS and the MS9590-106 meet the requirements for Full Speed USB hardware. These interfaces also support all emulation types previously supported in Low Speed USB scanners.

Additional Settings for EAS Equipped Models

All MS9590 models equipped with EAS capabilities have an EAS designation in their model numbers (example: MS9590-38-EAS). The cable supplied with these units will have additional wires for Checkpoint Device connections.

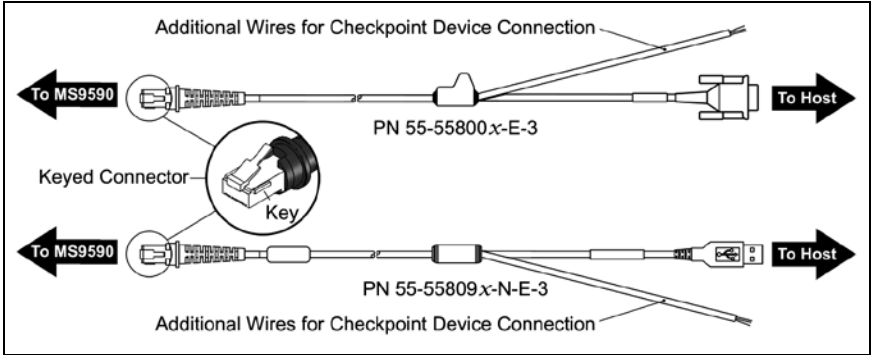

Figure 10. EAS Cable Samples

SW1 and SW2 are the switch banks inside the Checkpoint Device that set the deactivation range. The following is a list of Checkpoint recommended switch bank settings.

Checkpoint Recommended Switch Bank Settings			
SW1		SW2	
Switches 1, 4, 5, and 6	ON	Switches 1, 4, 5, and 6	ON
Switches 2 and 3	OFF	Switches 2 and 3	OFF

Figure 11 shows the location of the EAS deactivation area.

It is important to pass the entire tag through this area to deactivate the security tag.

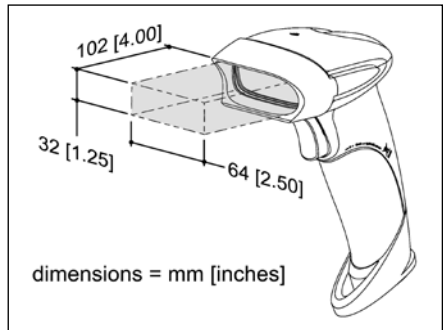

Figure 11. EAS Deactivation Area

STANDS

Flex Stand Components (PN 46-00709)

Item	Item Description	Qty.
A	Cradle Coupler	1
B	Cradle	1
C	Flexible Shaft	1
D	Screw Cap	2
E	Stand Base	1
F	1/4" - 20 x 3/8" Flat Head Phillips Screw, 100° Undercut	2
G	#8 Round Head Wood Screw	2
H	M3 -.5 x 20 mm, Pan Head Phillips Screw	1
J	M3 Flat Washer	1
K	M3 Split Lock Washer	1
L	Flexible Shaft Cover	1

Figure 12. Stand Components

Flex Stand Assembly (PN 46-00709)

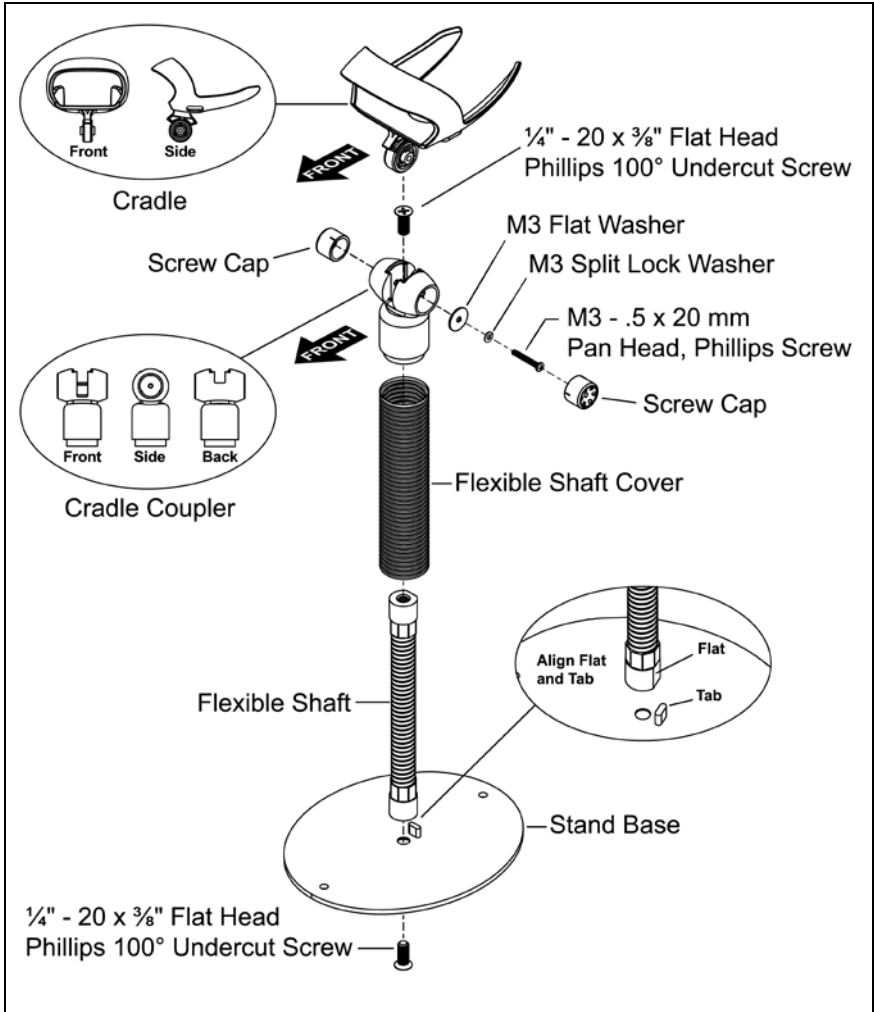

Figure 13. Stand Assembly

STANDS

Optional Flex Stand Fixed Mount (PN 46-00709)

1. In the kit, two #8 wood screws have been provided for fixed mount applications.
2. When choosing the stand location, make sure to consider the front orientation of the stand (indicated in *Figure 14*).
3. On a centerline, drill two #39 pilot holes in the countertop spaced 125 mm (4.92") apart. The stand base can be used as a guide for the spacing of the pilot holes.
4. Secure the stand base to the countertop with the two #8 wood screws provided.

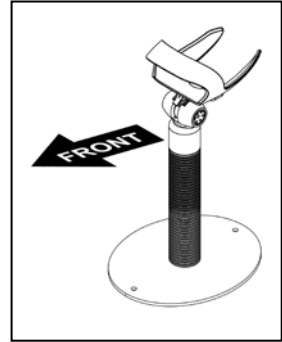

Figure 14.

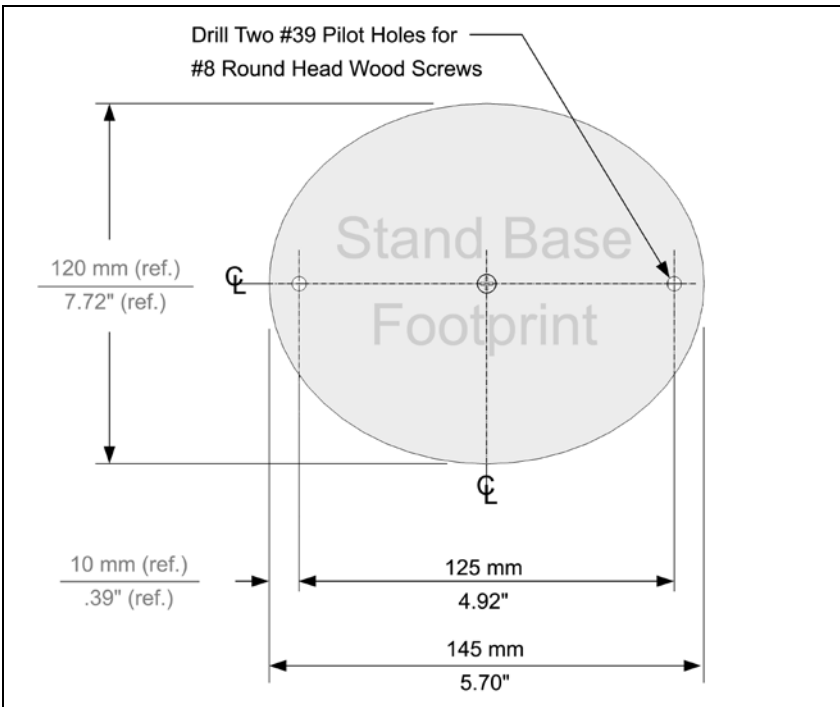

Figure 15. Stand Base Hole Pattern (Not to Scale)

Optional Wall/Tabletop Stand Fixed Mount (PN 46-00885)

1. Drill two #39 pilot holes in the wall spaced 39 mm (1.54") apart on a horizontal centerline.
2. Install one #8 wood screw in each of the pilot holes, leaving a space between the head of the screw and the wall surface.
3. Locate the two slots marked as "A" on the stand base in *Figure 16*.
4. Match the "A" slots on the stand to the heads of the installed wood screws.
5. Slide the stand over the screw heads and down to lock the stand in place.

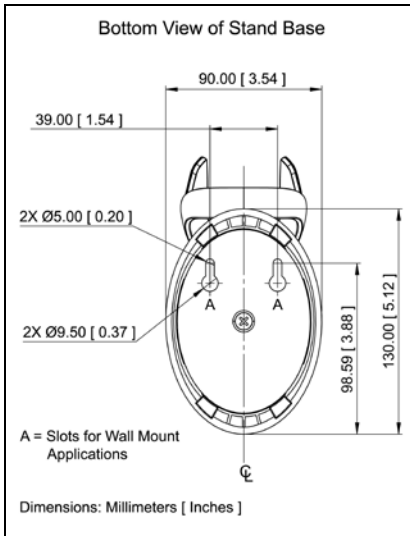

Figure 16.

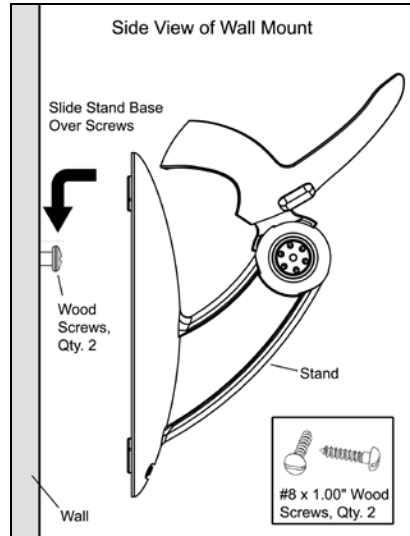

Figure 17

Cradle Angle Warning

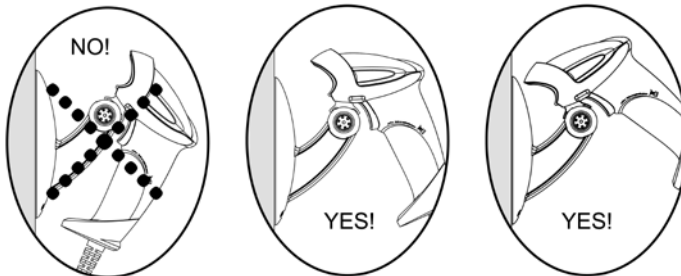

Figure 18. Cradle Angle Warning

SCANNER OPERATION

Default Modes of Operation

There are two default modes of operation available with the MS9590 series.

1. In-Stand, Automatic Activation Mode
 - The laser is activated upon object detection in the IR activation area.
 - Bar code data is automatically decoded and transmitted.
2. Out-of-Stand, Manual Activation Mode
 - The trigger (CodeGate) activates the laser.
 - Bar code data is scanned and transmitted while the trigger is held down.

Scanning with the Manual Activation Mode

1. Aim the scanner at the bar code.
2. Pull and hold down the trigger to turn on the laser, scan, and transmit the bar code.
3. The scanner will beep and flash the white LED once to indicate a successful scan and transmission.

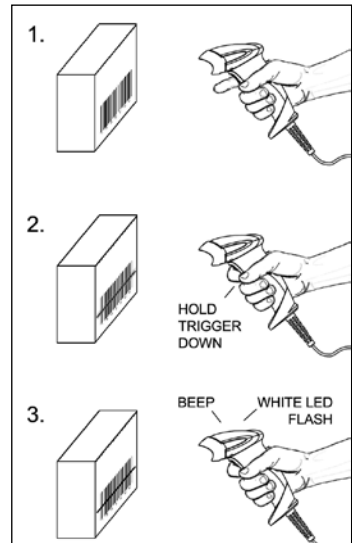

Figure 19.

Maintenance

Smudges and dirt on the unit's window can interfere with the unit's performance. If the window requires cleaning, use only a mild glass cleaner containing no ammonia. When cleaning the window, spray the cleaner onto a lint free, non-abrasive cleaning cloth then gently wipe the window clean.

If the unit's case requires cleaning, use a mild cleaning agent that does not contain strong oxidizing chemicals. Strong cleaning agents may discolor or damage the unit's exterior.

Audible

During operation, the scanner provides audible feedback that indicates the status of the scanner and latest scan. Eight settings are available for the tone of the beep (normal, six alternate tones and no tone). To change the beeper tone, refer to the MetroSelect Single-Line Configuration Guide or MetroSet2's help files.

One Beep

When the scanner *first* receives power, the blue LED will turn on, the white LED will flash, and the scanner will beep once. The scanner is ready to scan.

When the scanner successfully reads a bar code, the white LED will flash and the scanner will beep once.

Three Beeps

During Operation

When entering the configuration mode, the white LED will flash while the scanner simultaneously beeps three times.

When exiting the configuration mode, the scanner will beep three times and the white LED will stop blinking.

Three beeps can also indicate a communication timeout during normal scanning mode if the scanner is configured to give this indication.

During Start-up

This is a failure indicator. Refer to "Failure Modes" on page 20.

Three Beeps

When using the single-code-configuration method, the scanner will sound a 3-combination tone (a single beep then a short pause followed by, a high tone, and a low tone). This beep sequence signals that the single configuration bar code has successfully configured the scanner.

Razzberry Tone

This tone indicates a type of failure. Refer to "Failure Modes" on page 20.

When in configuration mode, a short razzberry tone will sound if an invalid bar code is scanned.

INDICATORS

Visual

Each MS9590 series scanner has three LED indicators (blue, white, and yellow) located on the head of the scanner. When the scanner is in operation, the flashing, or stationary activity of the LEDs indicates the status of the scanner and the current scan.

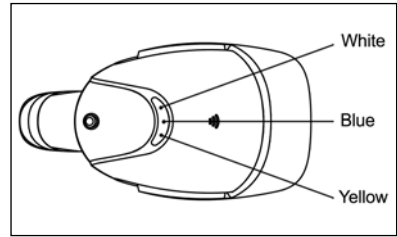

Figure 20. LED Configuration

All LEDs are Off

The LEDs will not be illuminated if the scanner is not receiving power from the host or transformer.

The scanner is in manual activation mode.

Steady Yellow

The scanner is in automatic scanning mode.

Steady Blue

When the laser is active, the blue LED is illuminated. The blue LED will remain illuminated until the laser is deactivated (*default mode only*).

Steady Blue and Single White Flash

When the scanner successfully reads a bar code, the white LED will flash and the scanner will beep once.



After a successful scan, the scanner transmits the data to the host device. Some communication modes require that the host inform the scanner when data is ready to be received. If the host is not ready to accept the information, the scanner's white LED will remain on until the data can be transmitted.

Alternating Flashing of Blue and White

During Operation

This indicates the scanner is in configuration mode.

Failure Modes

One Razzberry Tone – On Power Up

This indicates the scanner has experienced a flipper/motor failure. Return the scanner for repair to an authorized service center.

Three Beeps – On Power Up

If the scanner beeps three times on power up, verify the host and scanner are set to the same communication protocol.

If the host and the scanner's communication protocol match, then, the non-volatile memory (NovRAM) that holds the scanner's configuration may have failed. Try to reconfigure the scanner. If the scanner does not respond after reconfiguring, return the scanner for repair to an authorized service center.

CONFIGURATION MODES

The MS9590 series scanners have three modes of configuration.

- **Bar Codes**

Configure the 9590 by scanning the bar codes included in the MetroSelect Configuration Guide shipped with the scanner.

This manual is available for download at www.honeywellaidc.com.

- **MetroSet2**

This user-friendly Windows-based configuration program allows you to simply 'point-and-click' at the desired scanner options. This program is available for download at www.honeywellaidc.com.

- **Serial Programming**

This mode of configuration is ideal for OEM applications. This mode gives the end-user the ability to send a series of commands using the serial port of the host system. The commands are equivalent to the numerical values of the bar codes located in the MetroSelect Configuration Guide.

UPGRADING THE FLASH ROM FIRMWARE

The MS9590 and the MS9591 are part of Honeywell's line of scanners with flash upgradeable firmware. The upgrade process requires a new firmware file supplied to the customer by a customer service representative and MetroSet2 software♦. A personal computer running Windows 95 or greater with an available RS232 serial or USB port is also required to complete the upgrade.



PowerLink Cable #54-54014 is required when using RS232 for the upgrade process. This cable can be ordered from Honeywell. **Do not** use the standard cable supplied with keyboard wedge or RS485 scanner interface kits. If using USB for the upgrade process, the standard USB Type A cable provided with the scanner can be used.

Warning!

Do not disconnect the cable or turn off power to the scanner during the flash upgrade process. Failure to comply with this warning will cause a critical scanner failure.

To upgrade the firmware in the MS9590 or MS9591:

1. Plug the scanner into a serial communication port on the host system.
 2. Start the MetroSet2 software.
 3. Click on the plus sign (+) next to *POS Scanners* to expand the supported scanner list.
 4. Choose the *VoyagerGS 9590/9590i Series* from the list.
 5. Click on the *Configure VoyagerGS 9590/9590i Series Scanner* button.
 6. Choose *Flash Utility* from the options list located on the left side of the screen.
 7. Click on the *Open File* button in the Flash Utility window.
 8. Locate and open the flash upgrade file supplied.
 9. Select the COM port that the scanner is connected to on the host system.
 10. Verify the settings listed in the Flash Utility window.
 11. Click on the *Flash Scanner* button to begin the flash upgrade.
 12. A message will appear on the screen when the upgrade is complete.
- ♦ MetroSet2 is available for download, at no additional cost, from www.honeywellaidc.com.

DEPTH OF FIELD

MS9590

Bar Code Element Width		Depth of Field (In the Field of View)		
		Start (From Scanner Face)	End (From Scanner Face)	Total
.127 mm	5.0 mil	83 mm (3.3")	108 mm (4.3")	25 mm (1.0")
.15 mm	5.7 mil	64 mm (2.5")	127 mm (5.0")	63 mm (2.5")
.19 mm	7.5 mil	38 mm (1.5")	178 mm (7.0")	140 mm (5.5")
.26 mm	10.4 mil	32 mm (1.3")	254 mm (10.0")	222 mm (8.7")
.33 mm	13 mil	0 mm (0")	305 mm (12.0")	305 mm (12.0")
.48 mm	19 mil	0 mm (0")	406 mm (16.0")	406 mm (16.0")
.66 mm	26 mil	12 mm (0.5")	445 mm (17.1")	433 mm (16.6")

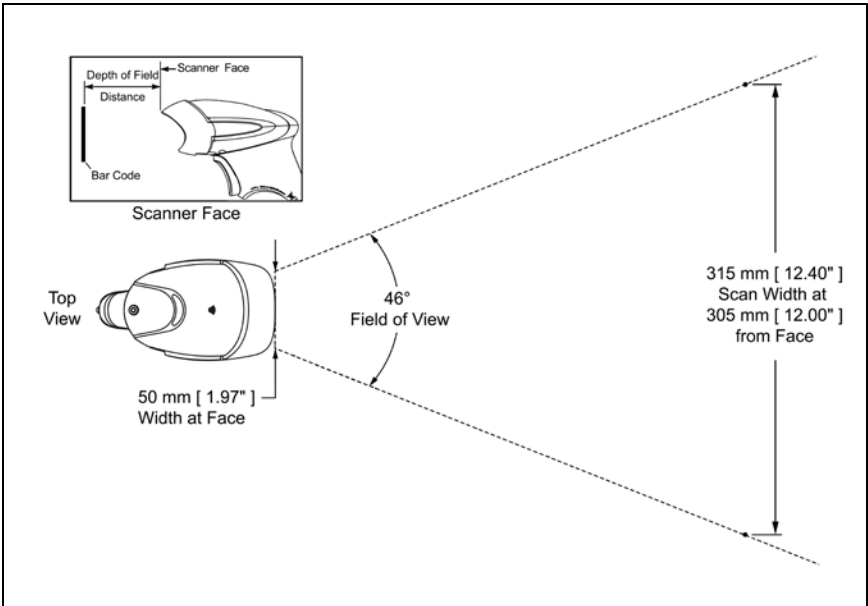

Figure 21. MS9590 Depth of Field vs. Bar Code Element Width

Specifications are subject to change without notice.

DEPTH OF FIELD

MS9591

Bar Code Element Width		Depth of Field (In the Field of View)		
		Start (From Scanner Face)	End (From Scanner Face)	Total
.10 mm	4.0 mil	25 mm (1.0")	45 mm (1.8")	20 mm (.8")
.12 mm	4.8 mil	23 mm (0.9")	51 mm (2.0")	28 mm (1.1")
.13 mm	5.2 mil	22 mm (0.9")	55 mm (2.2")	33 mm (1.3")
.19 mm	7.5 mil	20 mm (0.8")	64 mm (2.5")	44 mm (1.7")
.26 mm	10.4 mil	0 mm (0")	72 mm (2.8")	72 mm (2.8")
.33 mm	13 mil	0 mm (0")	100 mm (4.0")	100 mm (4.0")

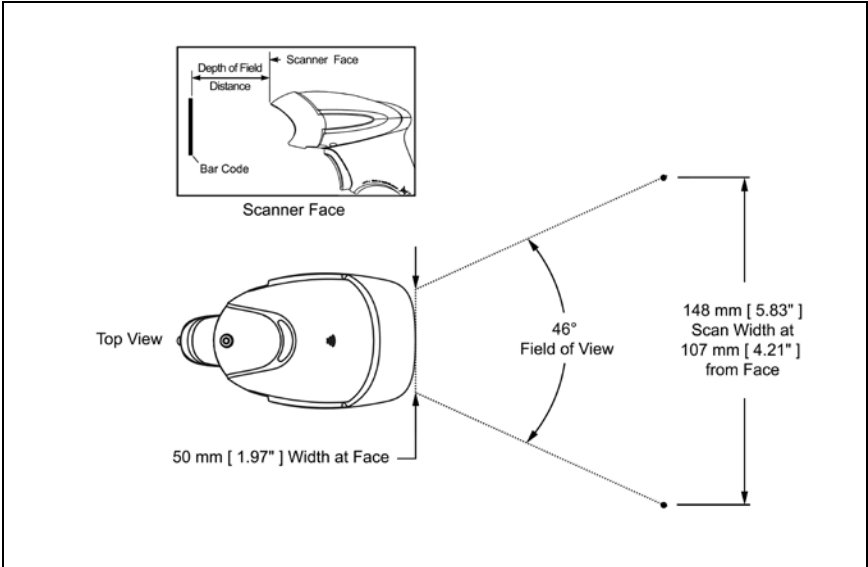

Figure 22. MS9591 Depth of Field vs. Bar Code Element Width

Specifications are subject to change without notice.

IR ACTIVATION RANGE

The MS9590 series has a built in object detection sensor that instantly turns on the scanner's laser when an object is presented within the scanner's IR activation area. Refer to the MetroSelect Single-Line Configuration Guide for information on configurable IR activation range options.

MS9590

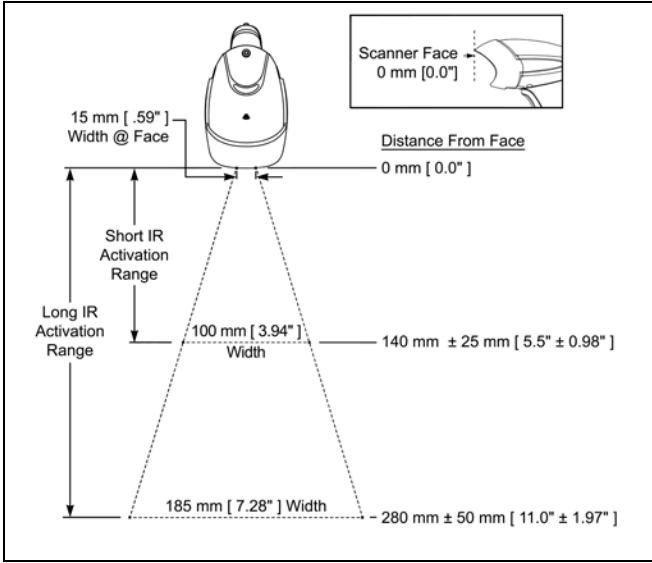

Figure 23. MS9590 IR Activation Areas

MS9591

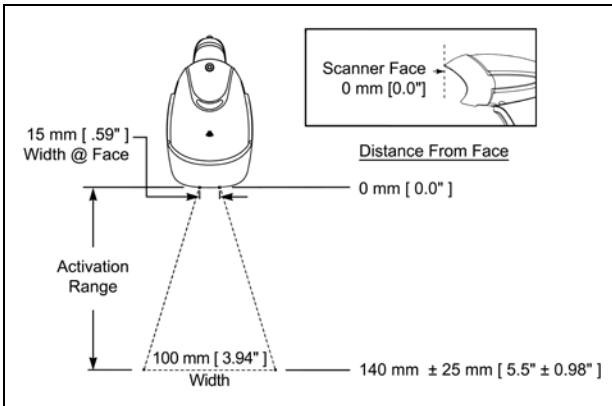

Figure 24. MS9591 IR Activation Area

Specifications are subject to change without notice.

APPLICATIONS AND PROTOCOLS

The model number on each scanner includes the scanner number and the default communication protocol for the scanner.

Scanner	Version Identifier	Communication Protocol(s)
MS9590 Or MS9591 (High Density Model)	14	RS232 - TXD, RXD, RTS, CTS, DTR, DSR
	47	Keyboard Wedge, Stand-Alone Keyboard and RS232 Transmit/Receive
	106	RS485 [◇] , USB (Bi-Directional Serial Emulation Mode, Keyboard Emulation Mode or IBM [®] OEM) and RS232 Transmit/Receive
EAS Equipped Models		
MS9590	38-EAS	USB (Bi-Directional Serial Emulation Mode or Keyboard Emulation Mode) and RS232 Transmit/Receive with EAS
	40-EAS	USB IBM [®] OEM with EAS

The MS9590 Keyboard Wedge Series (-47) is designed for keyboard emulation only. Many RS232 configurable functions available in other Honeywell scanners are also available as keyboard wedge functions.

The following items are the most important selectable options specific to the keyboard wedge interface:

Keyboard Type

- **AT (includes IBM[®] PS2 models 50, 55, 60, 80)
- IBM PS2 (includes models 30, 70, 8556)

Keyboard Country Type

- **USA
- Belgian
- French
- German
- Hungarian
- Italian
- Japanese
- Russian Cyrillic
- Slovenian
- Spanish
- Swiss
- Swedish/Finnish
- Turkish
- United Kingdom

[◇] Applicable for IBM[®] host applications

** Indicates a default setting. Refer to the MetroSelect Single-Line Configuration Guide (PN 00-02544) or MetroSet2's help files for information on how to change the default settings.

TROUBLESHOOTING GUIDE

The following guide is for reference purposes only. Contact a customer service representative to preserve the limited warranty terms.

Symptoms	Possible Causes	Solution
<i>All Interfaces</i>		
The unit has no LEDs, beep, or laser.	No power is being supplied to the unit.	Check the transformer, the outlet and power strip. Make sure the cable is plugged into the unit.
	No power is being supplied to the unit from host.	Some host systems cannot supply enough current to power Voyager. A power supply may be needed.
At power up, the unit beeps 3 times.	The host and scanner are not set to the same communication protocol.	Set the host and scanner to the same communication protocol.
	There is a non-volatile RAM failure.	Contact a service representative.
At power up, the unit emits a razz tone and the blue LED flashes.	The unit has experienced a VLD failure.	Contact a service representative.
At power up, the unit emits a razz tone and both LEDs flash.	The unit has experienced a flipper/motor failure.	
The unit scans, communicates, and beeps twice.	The same symbol timeout is set too short.	Adjust the same symbol timeout for a longer time.
The unit powers up, but does not beep.	The beeper may be disabled or no tone has been selected.	Enable beeper and select a tone.
The unit powers up, but does not scan and/or beep.	The unit is trying to scan a particular symbology that is not enabled.	UPC/EAN, Code 39, interleaved 2 of 5, Code 93, Code 128 and Codabar are enabled by default. Verify that the type of bar code being read has been selected.

TROUBLESHOOTING GUIDE

Symptoms	Possible Causes	Solution
The unit powers up, but does not scan and/or beep.	The bar code being scanned does not satisfy the configured criteria for character length lock or minimum length.	Verify that the bar code being scanned falls into the configured criteria. <i>The scanner defaults to a minimum of 3 character bar code.</i>
The following item is only relevant for RS232 and Serial Emulation USB interfaces.		
The unit scans a bar code, but locks up after the first scan and the white LED stays on.	The unit is configured to support some form of host handshaking but is not receiving the signal.	If the unit is setup to support ACK/NAK, RTS/CTS, XON/XOFF or D/E, verify that the host cable and host are supporting the handshaking properly.
The unit scans, but the data transmitted to the host is incorrect.	The unit's data format does not match the host system's requirements.	Verify that the unit's data format matches that required by the host. Make sure that the unit is connected to the proper host port.
The unit beeps at some bar codes but NOT for others of the same bar code symbology.	The print quality of the bar code is suspect.	Check the print mode. The type of printer could be the problem. Change the print settings. i.e. Change to econo mode or high speed.
	The aspect ratio of the bar code is out of tolerance.	
	The bar code may have been printed incorrectly.	Check if it is a check digit/character/or border problem.
	The unit is not configured correctly for the type of bar code being scanned.	
	The minimum symbol length setting does not work with the bar code.	Check if the correct minimum symbol length is set.
The unit scans the bar code but there is no data.	The unit's configuration is not set correctly.	Make sure the scanner is configured for the appropriate mode.

TROUBLESHOOTING GUIDE

Symptoms	Possible Causes	Solution
The next four items are only relevant for a Keyboard Wedge interface.		
The unit scans but the data is not correct.	The unit's configuration is not correct.	Make sure that the proper PC type AT, PS2 or XT is selected. Verify the correct country code and data format is selected. Adjust the inter-character delay symptom.
The unit is transmitting each character twice.	The unit's configuration is not correct.	Increase the interscan code delay setting. Adjust whether the F0 break is transmitted. It may be necessary to try this in both settings.
Alpha characters show as lower case.	The computer is in <i>Caps Lock</i> mode.	Enable the <i>Caps Lock</i> detect feature of the scanner to detect whether the PC is operating in Caps Lock.
Everything works except for a couple of characters.	These characters may not be supported by that country's key look up table.	Try operating the scanner in Alt mode.
The following item is only relevant for an RS232 interface.		
The unit powers-up OK and scans OK but does not communicate properly to the host.	The com port at the host is not working or not configured properly.	Check to make sure that the baud rate and parity of the scanner and the communication port match and that the program is looking for "RS232" data.
The unit powers-up OK and scans OK but does not communicate properly to the host.	The cable is not connected to the proper com port.	Check to make sure that the unit is connected to the correct com port on the host device.
The host is receiving data but the data does not look correct.	The scanner and host may not be configured for the same interface parameters.	Check that the scanner and the host are configured for the same interface parameters.
Characters are being dropped.	Inter-character delay needs to be added to the transmitted output.	Add some inter-character delay to the transmitted output by using the MetroSelect Single-Line Configuration Guide.

DESIGN SPECIFICATIONS

		MS9590 Series Specifications		
OPERATIONAL				
Light Source:	Visible Laser Diode 650 nm ± 10 nm			
Laser Power:	0.809 mW (peak)			
Pulse Duration:	560 µsec			
Depth of Scan Field:	MS9590	Refer to page 23		
	MS9591	Refer to page 24		
Width of Scan Field:	MS9590	Refer to page 23		
	MS9591	Refer to page 24		
Scan Speed:	100 scan lines per second			
Scan Pattern:	Single Scan Line			
Minimum Bar Width:	MS9590	0.127 mm (5.0 mil)		
	MS9591	0.075 mm (3.0 mil)		
Infrared Activation:	MS9590	Refer to page 25		
	MS9591	Refer to page 25		
Decode Capability:	Autodiscriminates all standard 1D bar codes for others call a service representative.			
System Interfaces:	RS232, Keyboard Wedge, Stand-Alone Keyboard, RS485 [◇] , USB			
Print Contrast:	35% minimum reflectance difference			
Number Characters Read:	Up to 80 data characters. The maximum number will vary based on symbology & density.			
Beeper Operation:	7 tones or no beep			
Visual Indicators: (Default Settings)	Blue LED	laser on, ready to scan		
	White LED	good read		
	Yellow LED	ON	Automatic Scanning Mode	
		OFF	Manual Activation Mode	

Specifications are subject to change without notice.

◇ Applicable for IBM® host applications

DESIGN SPECIFICATIONS

		MS9590 Series Specifications	
MECHANICAL			
Height H ¹ :	160 mm (6.30")		
H ² :	41 mm (1.60")		
Width W ¹ :	65 mm (2.56")		
W ² :	25.4 mm (1.00")		
Depth:	100 mm (3.93")		
Weight:	150g		
ELECTRICAL			
Input Voltage:	5VDC ± 0.25V		
Power:	Operating = 650 mW typical Standby = 375 mW typical		
Current:	Operating = 130 mA @ 5VDC typical Standby = 75 mA @ 5VDC typical		
DC Transformers:	Class 2; 5.2V @ 1A		
<i>For regulatory compliance information see pages 36 – 38.</i>			
ENVIRONMENTAL			
Temperature:	Operating = 0°C to 40°C (32°F to 104°F) Storage = -40°C to 60°C (-40°F to 140°F)		
Humidity:	5% to 95% relative humidity, non-condensing		
Light Levels:	Up to 4842 Lux (450 footcandles)		
Shock:	Designed to with stand 1.5 m (5 ft.) drops		
Environmental: Sealing	IP31		

Specifications are subject to change without notice.

SCANNER AND CABLE TERMINATIONS

Scanner Pinout Connections

The MS9590 and MS9591 scanner interfaces terminate to a 10-pin modular jack. The serial number label indicates the interface enabled when the scanner is shipped from the factory.

MS9590-14 or MS9591-14 RS232	
Pin	Function
1	Ground
2	Transmit RS232 Output
3	Receive RS232 Input
4	RTS RS232 Output
5	CTS RS232 Input
6	DTR RS232 Input
7	Reserved
8	DSR TTL Output
9	+5VDC
10	Shield Ground

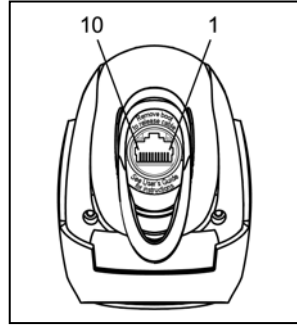

Figure 25.

MS9590-47 or MS9591-47 Keyboard Wedge and Stand-Alone Keyboard	
Pin	Function
1	Ground
2	Transmit RS232 TTL Output
3	Receive RS232 TTL Input
4	PC Data TTL
5	PC Clock TTL
6	KB Clock TTL
7	Reserved
8	KB Data TTL
9	PC +5VDC
10	Shield Ground

MS9590-38-EAS USB and RS232 Transmit/Receive with EAS	
Pin	Function
1	Ground
2	Transmit RS232 Output
3	Receive RS232 Input
4	EAS -
5	EAS+
6	D+
7	PC +5V Detect Input
8	D-
9	PC +5V Power
10	Shield Ground

MS9590-106 or MS9591-106 RS485*, USB	
Pin	Function
1	Ground
2	Transmit RS232 TTL Output
3	Receive RS232 TTL Input
4	IBM +
5	IBM -
6	D+
7	PC +5V Detect Input
8	D-
9	PC +5V Power
10	Shield Ground



MS9590-40-EAS USB RS485* OEM with EAS	
Pin	Function
1	Ground
2	Transmit RS232 Output
3	Receive RS232 Input
4	EAS -
5	EAS+
6	D+
7	PC +5V Detect Input
8	D-
9	PC +5V Power
10	Shield Ground

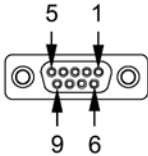

* Applicable for IBM® host applications

SCANNER AND CABLE TERMINATIONS

Cable Connector Configuration (Host End)



RS232 PowerLink Cable 53-53000x-3		
Pin	Function	 <p>9-Pin Female, D-Type</p>
1	Shield Ground	
2	RS232 Transmit Output	
3	RS232 Receive Input	
4	DTR Input/Light Pen Source	
5	Signal Ground	
6	Light Pen Data (DSR Out for -14 interfaces)	
7	CTS Input	
8	RTS Output	
9	+5VDC	

USB Cables 53-53813x-N-3, 53-53809x-N-3			
Pin	Function	 <p>Locking Type A</p>	 <p>Non-Locking Type A</p>
1	PC +5V/V_USB		
2	D-		
3	D+		
4	Ground		
Shield	Shield		



Stand-Alone Keyboard Cable 53-53820x-N-3		
Pin	Function	 <p>6-Pin Male Mini-DIN Connector</p>
1	PC Data	
2	No Connect	
3	Power Ground	
4	+5VDC PC Power to KB	
5	PC Clock	
6	No Connect	

SCANNER AND CABLE TERMINATIONS

Cable Connector Configuration (Host End)

Keyboard Wedge Cable 53-53802x-3		
Pin	Function	 5-Pin DIN, Female
1	Keyboard Clock	
2	Keyboard Data	
3	No Connect	
4	Power Ground	
5	+5 Volts DC	
Pin	Function	 6-Pin DIN, Male
1	PC Data	
2	No Connect	
3	Power Ground	
4	+5 Volts DC	
5	PC Clock	
6	No Connect	

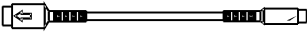
Honeywell will supply an adapter cable with a 5-pin DIN male connector on one end and a 6-pin mini DIN female connector on the other. According to the termination required, connect the appropriate end of the adapter cable to the PowerLink cable, leaving the necessary termination exposed for connecting to the keyboard and the keyboard port on the PC.

Keyboard Wedge Adapter Cable		
Pin	Function	 5-Pin DIN, Male
1	PC Clock	
2	PC Data	
3	No Connect	
4	Power Ground	
5	+5 Volts DC	
Pin	Function	 6-pin Mini DIN, Female
1	Keyboard Data	
2	No Connect	
3	Power Ground	
4	+5 Volts DC	
5	Keyboard Clock	
6	No Connect	

LIMITED WARRANTY

Honeywell International Inc. ("HII") warrants its products and optional accessories to be free from defects in materials and workmanship and to conform to HII's published specifications applicable to the products purchased at the time of shipment. This warranty does not cover any HII product which is (i) improperly installed or used; (ii) damaged by accident or negligence, including failure to follow the proper maintenance, service, and cleaning schedule; or (iii) damaged as a result of (A) modification or alteration by the purchaser or other party, (B) excessive voltage or current supplied to or drawn from the interface connections, (C) static electricity or electro-static discharge, (D) operation under conditions beyond the specified operating parameters, or (E) repair or service of the product by anyone other than HII or its authorized representatives.

This warranty shall extend from the time of shipment for the duration published by HII for the product at the time of purchase ("Warranty Period"). Any defective product must be returned (at purchaser's expense) during the Warranty Period to HII factory or authorized service center for inspection. No product will be accepted by HII without a Return Materials Authorization, which may be obtained by contacting HII. In the event that the product is returned to HII or its authorized service center within the Warranty Period and HII determines to its satisfaction that the product is defective due to defects in materials or workmanship, HII, at its sole option, will either repair or replace the product without charge, except for return shipping to HII.

EXCEPT AS MAY BE OTHERWISE PROVIDED BY APPLICABLE LAW, THE FOREGOING WARRANTY IS IN LIEU OF ALL OTHER COVENANTS OR WARRANTIES, EITHER EXPRESSED OR IMPLIED, ORAL OR WRITTEN, INCLUDING, WITHOUT LIMITATION, ANY IMPLIED WARRANTIES OF MERCHANTABILITY OR FITNESS FOR A PARTICULAR PURPOSE, OR NON-INFRINGEMENT.

HII'S RESPONSIBILITY AND PURCHASER'S EXCLUSIVE REMEDY UNDER THIS WARRANTY IS LIMITED TO THE REPAIR OR REPLACEMENT OF THE DEFECTIVE PRODUCT WITH NEW OR REFURBISHED PARTS. IN NO EVENT SHALL HII BE LIABLE FOR INDIRECT, INCIDENTAL, OR CONSEQUENTIAL DAMAGES, AND, IN NO EVENT, SHALL ANY LIABILITY OF HII ARISING IN CONNECTION WITH ANY PRODUCT SOLD HEREUNDER (WHETHER SUCH LIABILITY ARISES FROM A CLAIM BASED ON CONTRACT, WARRANTY, TORT, OR OTHERWISE) EXCEED THE ACTUAL AMOUNT PAID TO HII FOR THE PRODUCT. THESE LIMITATIONS ON LIABILITY SHALL REMAIN IN FULL FORCE AND EFFECT EVEN WHEN HII MAY HAVE BEEN ADVISED OF THE POSSIBILITY OF SUCH INJURIES, LOSSES, OR DAMAGES. SOME STATES, PROVINCES, OR COUNTRIES DO NOT ALLOW THE EXCLUSION OR LIMITATIONS OF INCIDENTAL OR CONSEQUENTIAL DAMAGES, SO THE ABOVE LIMITATION OR EXCLUSION MAY NOT APPLY TO YOU.

All provisions of this Limited Warranty are separate and severable, which means that if any provision is held invalid and unenforceable, such determination shall not affect the validity of enforceability of the other provisions hereof. Use of any peripherals not provided by the manufacturer may result in damage not covered by this warranty. This includes but is not limited to: cables, power supplies, cradles, and docking stations. HII extends these warranties only to the first end-users of the products. These warranties are non-transferable.

The duration of the limited warranty for the 9590 VoyagerGS is five (5) years. The accessories have a 90 day limited warranty from the date of manufacture

Safety

ITE Equipment

IEC 60950-1:2005, EN 60950-1:2006+A11:2009

Laser

Laser Class 1: IEC 60825-1:2007,
EN 60825-1:2007



LED

IEC 62471:2006 EXEMPT RISK GROUP

Caution

Use of controls or adjustments or performance of procedures other than those specified herein may result in hazardous laser light exposure. Under no circumstances should the customer attempt to service the laser scanner. Never attempt to look at the laser beam, even if the scanner appears to be nonfunctional. Never open the scanner in an attempt to look into the device. Doing so could result in hazardous laser light exposure. The use of optical instruments with the laser equipment will increase eye hazard.

Atención

La modificación de los procedimientos, o la utilización de controles o ajustes distintos de los especificados aquí, pueden provocar una luz de láser peligrosa. Bajo ninguna circunstancia el usuario deberá realizar el mantenimiento del láser del escáner. Ni intentar mirar al haz del láser incluso cuando este no esté operativo. Tampoco deberá abrir el escáner para examinar el aparato. El hacerlo puede conllevar una exposición peligrosa a la luz de láser. El uso de instrumentos ópticos con el equipo láser puede incrementar el riesgo para la vista.

Attention

L'emploi de commandes, réglages ou procédés autres que ceux décrits ici peut entraîner de graves irradiations. Le client ne doit en aucun cas essayer d'entretenir lui-même le scanner ou le laser. Ne regardez jamais directement le rayon laser, même si vous croyez que le scanner est inactif. N'ouvrez jamais le scanner pour regarder dans l'appareil. Ce faisant, vous vous exposez à une rayonnement laser qu'il est dangereux. L'emploi d'appareils optiques avec cet équipement laser augmente le risque d'endommagement de la vision.

Achtung

Die Verwendung anderer als der hier beschriebenen Steuerungen, Einstellungen oder Verfahren kann eine gefährliche Laserstrahlung hervorrufen. Der Kunde sollte unter keinen Umständen versuchen, den Laser-Scanner selbst zu warten. Sehen Sie niemals in den Laserstrahl, selbst wenn Sie glauben, daß der Scanner nicht aktiv ist. Öffnen Sie niemals den Scanner, um in das Gerät hineinzusehen. Wenn Sie dies tun, können Sie sich einer gefährlichen Laserstrahlung aussetzen. Der Einsatz optischer Geräte mit dieser Laserausrüstung erhöht das Risiko einer Sehschädigung.

Safety

Attenzione

L'utilizzo di sistemi di controllo, di regolazioni o di procedimenti diversi da quelli descritti nel presente Manuale può provocare delle esposizioni a raggi laser rischiose. Il cliente non deve assolutamente tentare di riparare egli stesso lo scanner laser. Non guardate mai il raggio laser, anche se credete che lo scanner non sia attivo. Non aprite mai lo scanner per guardare dentro l'apparecchio. Facendolo potete esporVi ad una esposizione laser rischiosa. L'uso di apparecchi ottici, equipaggiati con raggi laser, aumenta il rischio di danni alla vista.

EMC

Emissions

FCC Part 15, ICES-003, CISPR 22, EN 55022

Immunity

CISPR 24, EN 55024

Note: Immunity performance is not guaranteed for scanner cables greater than 3 meters in length when fully extended.

Changes or modifications not expressly approved by the party responsible for compliance could void the user's authority to operate the equipment.

Class A Devices

The following is applicable when the scanner cable is greater in length than 3 meters (9.8 feet) when fully extended:

Les instructions ci-dessous s'appliquent aux cables de scanner dépassant 3 mètres (9.8 pieds) de long en extension maximale:

Folgendes trifft zu, wenn das Scannerkabel länger als 3 Meter ist:

This equipment has been tested and found to comply with limits for a Class A digital device, pursuant to part 15 of the FCC Rules. These limits are designed to provide reasonable protection against harmful interference when the equipment is operated in a commercial environment. This equipment generates, uses and can radiate radio frequency energy and, if not installed and used in accordance with the instruction manual, may cause harmful interference to radio communications. Operation of this equipment in a residential area is likely to cause harmful interference, in which case the user will be required to correct the interference at their own expense. Any unauthorized changes or modifications to this equipment could void the user's authority to operate this device.

This device complies with part 15 of the FCC Rules. Operation is subject to the following two conditions: (1) This device may not cause harmful interference, and (2) this device must accept any interference received, including interference that may cause undesired operation.

Notice

This Class A digital apparatus complies with Canadian ICES-003.

EMC

Remarque

Cet appareil numérique de classe A est conforme à la norme canadienne NMB-003.

European Standard

Warning

This is a class A product. In a domestic environment this product may cause radio interference in which case the user may be required to take adequate measures.

Funkstöreeigenschaften nach EN55022:1998

Warnung!

Dies ist eine Einrichtung der Klasse A. Diese Einrichtung kann im Wohnbereich Funkstörungen verursachen. In diesem Fall kann vom Betreiber verlangt werden, angemessene Massnahmen durchzuführen.

Standard Europeo

Attenzione

Questo e' un prodotto di classe A. Se usato in vicinanza di residenze private potrebbe causare interferenze radio che potrebbero richiedere all'utilizzatore opportune misure.

Attention

Ce produit est de classe "A". Dans un environnement domestique, ce produit peut être la cause d'interférences radio. Dans ce cas l'utiliseteur peut être amené à prendre les mesures adéquates.

Changes or modifications not expressly approved by the party responsible for compliance could void the user's authority to operate the equipment.

Class B Devices

The following is applicable when the scanner cable is less than 3 meters (9.8 feet) in length when fully extended:

Les instructions ci-dessous s'appliquent aux cables de scanner ne dépassant pas 3 mètres (9.8 pieds) de long en extension maximale:

Folgendes trifft zu, wenn das Scannerkabel kürzer als 3 Meter ist:

This device complies with Part 15 of the FCC Rules. Operation is subject to the following two conditions: (1) This device may not cause harmful interference, and (2) this device must accept any interference received, including interference that may cause undesired operation.

EMC

This equipment has been tested and found to comply with the limits for a Class B digital device, pursuant to Part 15 of the FCC rules. These limits are designed to provide reasonable protection against harmful interference in a residential installation. This equipment generates, uses and can radiate radio frequency energy and, if not installed and used in accordance with the instructions, may cause harmful interference to radio communications. However, there is no guarantee that interference will not occur in a particular installation. If this equipment does cause harmful interference to radio or television reception, which can be determined by turning the equipment off and on, the user is encouraged to try to correct the interference by one or more of the following measures:

- Reorient or relocate the receiving antenna
- Increase the separation between the equipment and receiver
- Connect the equipment into an outlet on a circuit different from that to which the receiver is connected
- Consult the dealer or an experienced radio/TV technician for help

Notice

This Class B digital apparatus complies with Canadian ICES-003.

Remarque

Cet appareil numérique de classe B est conforme à la norme canadienne NMB-003.

INDEX

A

AC *see power*
accessories 2, 3
adapter 3

B

beep *see indicator*
blue LED *see indicator*

C

cable 2–3, 27–29
 adapter 3
 communication 1, 2–3, 5, 7–11, 22, 29, 32–34
 EAS 12
 installation 5
 MVC 3, 8
 pin assignments 32–34
caution 6, 36
 labels 6
 laser 6, 36
CE *see caution*
CodeGate 1, 17, 19
communication 27–29
compliance 36–39
configuration 21, 26
converter 3
current 27, 31
customer service 35

D

default 26
depth of field 23–24

E

EAS 12
EMC 37
EMI 37
emissions 37

F

failure indicator *see indicator*

I

IBM *see RS485*

immunity 37
indicator
 audible 18, 22, 30
 failure 20, 18–20, 27–29
 visual 4, 19, 22, 27–29, 30
interface 30, 32–34
 Keyboard Wedge 1, 9, 22, 26, 32, 34
 RS232 1, 7, 26, 29, 32, 33
 RS485 1, 8, 22, 26, 32, 33
 Stand-Alone Keyboard . 1, 10, 22, 32, 33
 USB 1, 11, 22, 26, 32, 33
IR range 25

K

Keyboard Wedge *see interface*

L

labels 6
laser 30, 36–39, 36
LED *see indicator*
light level 31

M

maintenance 17
manual 2

O

output window 4

P

pin assignments *see cable*
power 2, 7–11, 22, 27, 31
PowerLink *see cable*
protocols *see interface*

R

regulatory compliance 36–39
repair 35
RMA 35
RS232 *see interface*
RS485 *see interface*

INDEX

S

safety..... 36
SELV *see caution*
serial number..... 6
specifications..... 30, 31
stand..... 2, 13–17
switch bank..... 12

T

termination..... 32–34
tones..... 19
troubleshooting..... 27–29

U

UL..... *see caution*
USB..... *see interface*

V

ventilation..... 31
voltage 2, 31, *see caution*

W

warranty 35
white LED..... *see indicator*
window..... 4, 17

Y

yellow LED..... *see indicators*

Product Service and Repair

Honeywell International Inc. provides service for all its products through service centers throughout the world. To obtain warranty or non-warranty service, contact the appropriate location below to obtain a Return Material Authorization number (RMA #) before returning the product.

North America

Telephone: (800) 782-4263

E-mail: hsmnaservice@honeywell.com

Latin America

Telephone: (803) 835-8000

Telephone: (800) 782-4263

Fax: (239) 263-9689

E-mail: laservice@honeywell.com

Brazil

Telephone: +55 (11) 5185-8222

Fax: +55 (11) 5185-8225

E-mail: brservice@honeywell.com

Mexico

Telephone: 01-800-HONEYWELL (01-800-466-3993)

Fax: +52 (55) 5531-3672

E-mail: mxservice@honeywell.com

Europe, Middle East, and Africa

Telephone: +31 (0) 40 2901 633

Fax: +31 (0) 40 2901 631

E-mail: euroservice@honeywell.com

Hong Kong

Telephone: +852-29536436

Fax: +851-2511-3557

E-mail: apservice@honeywell.com

Singapore

Telephone: +65-6842-7155

Fax: +65-6842-7166

E-mail: apservice@honeywell.com

China

Telephone: +86 800 828 2803

Fax: +86-512-6762-2560

E-mail: apservice@honeywell.com

Japan

Telephone: +81-3-6730-7344

Fax: +81-3-6730-7222

E-mail: apservice@honeywell.com

Online Product Service and Repair Assistance

You can also access product service and repair assistance online at www.honeywellaidc.com.

Technical Assistance

If you need assistance installing or troubleshooting your device, please contact us by using one of the methods below:

Knowledge Base: www.hsmknowledgebase.com

Our Knowledge Base provides thousands of immediate solutions. If the Knowledge Base cannot help, our Technical Support Portal (see below) provides an easy way to report your problem or ask your question.

Technical Support Portal: www.hsmsupportportal.com

The Technical Support Portal not only allows you to report your problem, but it also provides immediate solutions to your technical issues by searching our Knowledge Base. With the Portal, you can submit and track your questions online and send and receive attachments.

Web form: www.hsmcontactsupport.com

You can contact our technical support team directly by filling out our online support form. Enter your contact details and the description of the question/problem.

Telephone: www.honeywellaidc.com/locations

For our latest contact information, please check our website at the link above.

Honeywell Scanning & Mobility

9680 Old Bailes Road

Fort Mill, SC 29707

www.honeywellaidc.com



00-05150 Rev G
12/11