

Honeywell

Dolphin[®] 9900 Mobile Computers

Dolphin 9900

Dolphin 9950

Dolphin 9951

with Windows Mobile[®] 6.1

Quick Start Guide

Dolphin 9900 Series Quick Start Guide

Out of the Box

Verify that the box contains the following items:

- Dolphin 9900 or 9950 or 9951 mobile computer (the terminal)
- Main battery pack (7.4v Li-ion)
- Microsoft Getting Started CD

Note: If you ordered peripherals and/or accessories, verify that they are also included with the order.

Be sure to keep the original packaging in case the Dolphin terminal needs to be returned for service; for details, see page 6.

Front Panel

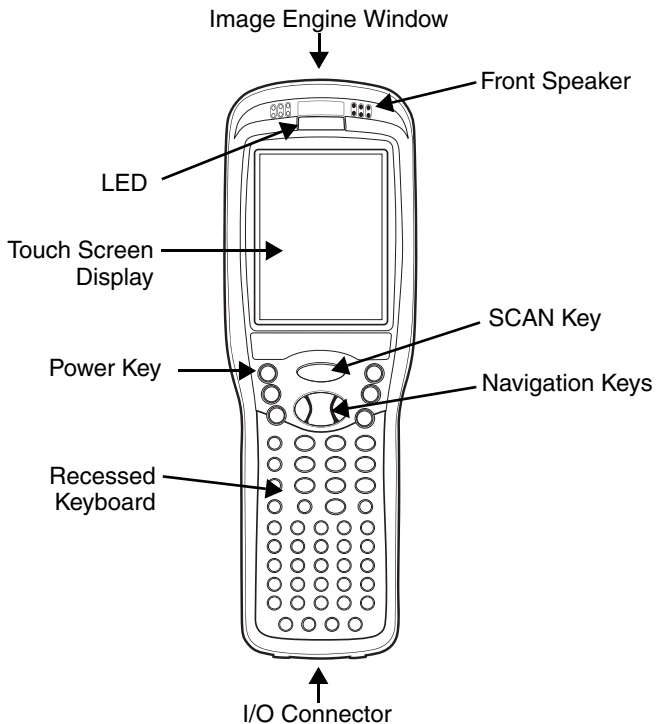

Back and Side Panels

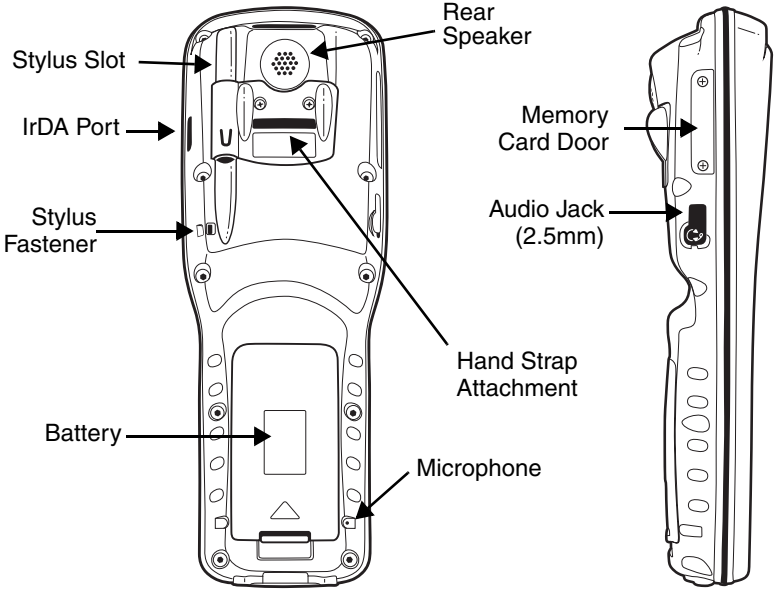

9950 and 9951 Back and Side Panels

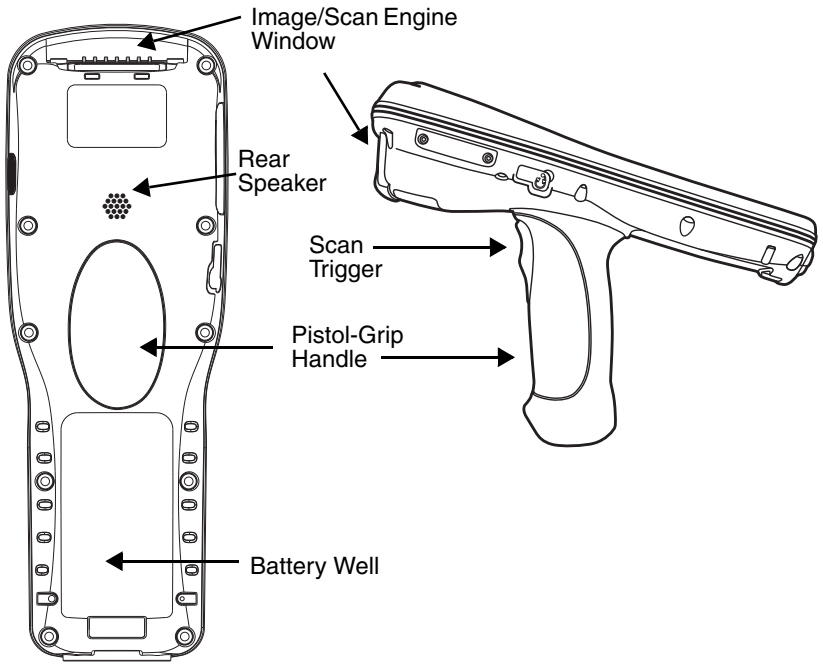

Setting up the Terminal

1. Install the battery in the terminal - see page 4.
2. Charge the main battery for a minimum of 4.5 hours - see page 4.
3. Boot the terminal - see page 5.

Step 1: Install the Main Battery Pack

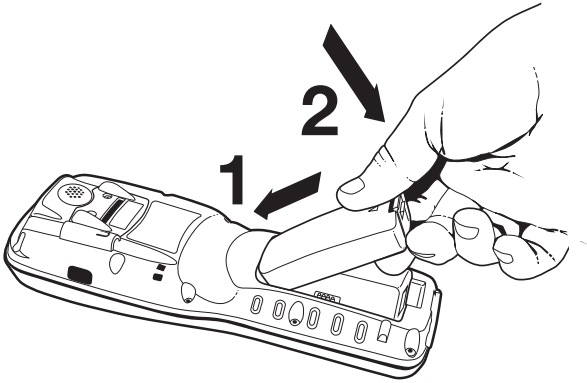

We recommend use of Honeywell Li-Ion battery packs. Use of any non-Honeywell battery may result in damage not covered by the warranty.

Step 2: Charge the Batteries

The power supply consists of two types of battery power: the main battery pack installed in the back panel and the backup battery located inside the terminal.

The main battery powers the terminal and charges the internal backup battery. The internal backup battery maintains the data stored in RAM memory and keeps the system clock running for up to 30 minutes when the main battery is completely discharged or removed.

Terminals are shipped with both batteries completely discharged. **Charge the main battery pack for a minimum of 4.5 hours before initial use in the terminal!**

Connect the terminal to a Dolphin 9900 powered charging peripheral - see page 5.

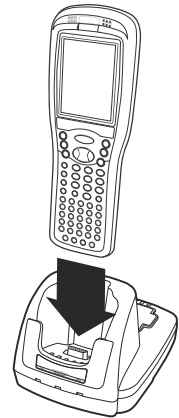

We recommend use of Honeywell peripherals, power cables, and power adapters. Use of any non-Honeywell peripherals, cables, or power adapters may cause damage not covered by the warranty.

Step 3: Boot the Terminal

The terminal begins booting as soon as power is applied and runs by itself. Do NOT press any keys or interrupt the boot process. Only tap the screen when prompted.

When the boot process is complete, the Today screen appears and the terminal is ready for use.

Note: Because the Today screen appears a number of times during the boot process, wait a few seconds before tapping anything on the Today screen.

Resetting the Terminal

- Soft Reset:** On the 56-key keyboard, press and hold the CTRL + SFT keys for approximately five seconds.
On the 43-key keyboard, press and hold the CTRL + NUM keys for approximately five seconds.
A soft reset re-boots the terminal without erasing RAM data.
- Hard Reset:** Press and hold the CTRL + ESC keys for approximately 5 seconds.
A hard reset erases all data and applications stored in RAM memory and re-initializes the terminal.

Peripherals and Accessories

- Dolphin HomeBase™ Device** Charging/communications cradle with auxiliary battery well. Data transfers via RS-232 serial or USB ports.
- Dolphin MobileBase™ Device** Mobile charging/communication cradle. RS-232 serial transfers data and powers out at 5 volts.
- Dolphin QuadCharger™ Device** Four-slot battery charger that charges four Li-ion batteries in less than five hours. One slot doubles as a battery analyzer.
- Dolphin Mobile Charger** Charges a Dolphin terminal by plugging into a vehicle cigarette lighter/power port.
- Dolphin Net Base** Four-slot charging/communication cradle designed for Ethernet-based communications.
- Dolphin ChargeBase** Four-slot charging cradle that stores, powers, and charges a terminal in each slot.
- Dolphin Cable Kits** USB or serial cables that charge and communicate with the terminal directly, without a cradle.

Technical Assistance

If you need assistance installing or troubleshooting your device, please call your distributor or the nearest technical support office:

North America/Canada

Telephone: (800) 782-4263
Fax number: (315) 554-6705
E-mail: natechsupport@honeywell.com

Latin America

Telephone: (803) 835-8000
Telephone: (800) 782-4263
E-mail: latechsupport@honeywell.com

Brazil

Telephone: +55 (21) 3535-9100
Fax: +55 (21) 3535-9105
E-mail: brsuporte@honeywell.com

Mexico

Telephone: (803) 835-8000
E-mail: latechsupport@honeywell.com

Europe, Middle East, and Africa

Telephone: +31 (0) 40 7999 393
Fax: +31 (0) 40 2425 672
E-mail: eurosupport@honeywell.com

Asia Pacific

Telephone - Hong Kong: +852-3188-3485 or 2511-3050
Telephone - China: +86 21 6361 3818
E-mail: aptechsupport@honeywell.com

Japan

Telephone: +813-3839-8511
E-mail: aptechsupport@honeywell.com

Malaysia

Telephone: +603-6201-7020
E-mail: aptechsupport@honeywell.com

Online Technical Assistance

You can also access technical assistance online at www.honeywellaidc.com.

Product Service and Repair

Honeywell International Inc. provides service for all its products through service centers throughout the world. To obtain warranty or non-warranty service, contact the appropriate location below to obtain a Return Material Authorization number (RMA #) before returning the product.

North America

Telephone: (800) 782-4263
Fax: (803) 835-8012
E-mail: naservice@honeywell.com

Latin America

Telephone: (803) 835-8000
Telephone: (800) 782-4263
Fax: (239) 263-9689
E-mail: laservice@honeywell.com

Brazil

Telephone: +55 (21) 3535-9100
Fax: +55 (21) 3535-9105
E-mail: brservice@honeywell.com

Mexico

Telephone: +52 (55) 5203-2100
Fax: +52 (55) 5531-3672
E-mail: mxservice@honeywell.com

Europe, Middle East, and Africa

Telephone: +31 (0) 40 2901 633
Fax: +31 (0) 40 2901 631
E-mail: euservice@honeywell.com

Asia Pacific

Telephone: +852-2511-3050
Fax: +852-2511-3557
E-mail: apservice@honeywell.com

Japan

Telephone: +813-3839-8511
Fax: +813-3839-8519
E-mail: apservice@honeywell.com

Online Product Service and Repair Assistance

You can also access product service and repair assistance online at www.honeywellaidc.com.

Limited Warranty

Honeywell International Inc. ("HII") warrants its products and optional accessories to be free from defects in materials and workmanship and to conform to HII's published specifications applicable to the products purchased at the time of shipment. This warranty does not cover any HII product which is (i) improperly installed or used; (ii) damaged by accident or negligence, including failure to follow the proper maintenance, service, and cleaning schedule; or (iii) damaged as a result of (A) modification or alteration by the purchaser or other party, (B) excessive voltage or current supplied to or drawn from the interface connections, (C) static electricity or electro-static discharge, (D) operation under conditions beyond the specified operating parameters, or (E) repair or service of the product by anyone other than HII or its authorized representatives.

This warranty shall extend from the time of shipment for the duration published by HII for the product at the time of purchase ("Warranty Period"). Any defective product must be returned (at purchaser's expense) during the Warranty Period to HII factory or authorized service center for inspection. No product will be accepted by HII without a Return Materials Authorization, which may be obtained by contacting HII. In the event that the product is returned to HII or its authorized service center within the Warranty Period and HII determines to its satisfaction that the product is defective due to defects in materials or workmanship, HII, at its sole option, will either repair or replace the product without charge, except for return shipping to HII.

EXCEPT AS MAY BE OTHERWISE PROVIDED BY APPLICABLE LAW, THE FOREGOING WARRANTY IS IN LIEU OF ALL OTHER COVENANTS OR WARRANTIES, EITHER EXPRESSED OR IMPLIED, ORAL OR WRITTEN, INCLUDING, WITHOUT LIMITATION, ANY IMPLIED WARRANTIES OF MERCHANTABILITY OR FITNESS FOR A PARTICULAR PURPOSE, OR NON-INFRINGEMENT.

HII'S RESPONSIBILITY AND PURCHASER'S EXCLUSIVE REMEDY UNDER THIS WARRANTY IS LIMITED TO THE REPAIR OR REPLACEMENT OF THE DEFECTIVE PRODUCT WITH NEW OR REFURBISHED PARTS. IN NO EVENT SHALL HII BE LIABLE FOR INDIRECT, INCIDENTAL, OR CONSEQUENTIAL DAMAGES, AND, IN NO EVENT, SHALL ANY LIABILITY OF HII ARISING IN CONNECTION WITH ANY

PRODUCT SOLD HEREUNDER (WHETHER SUCH LIABILITY ARISES FROM A CLAIM BASED ON CONTRACT, WARRANTY, TORT, OR OTHERWISE) EXCEED THE ACTUAL AMOUNT PAID TO HII FOR THE PRODUCT. THESE LIMITATIONS ON LIABILITY SHALL REMAIN IN FULL FORCE AND EFFECT EVEN WHEN HII MAY HAVE BEEN ADVISED OF THE POSSIBILITY OF SUCH INJURIES, LOSSES, OR DAMAGES. SOME STATES, PROVINCES, OR COUNTRIES DO NOT ALLOW THE EXCLUSION OR LIMITATIONS OF INCIDENTAL OR CONSEQUENTIAL DAMAGES, SO THE ABOVE LIMITATION OR EXCLUSION MAY NOT APPLY TO YOU.

All provisions of this Limited Warranty are separate and severable, which means that if any provision is held invalid and unenforceable, such determination shall not affect the validity of enforceability of the other provisions hereof. Use of any peripherals not provided by the manufacturer may result in damage not covered by this warranty. This includes but is not limited to: cables, power supplies, cradles, and docking stations. HII extends these warranties only to the first end-users of the products. These warranties are non-transferable.

The limited duration of the warranty for the Dolphin 9900, 9950, and 9951 is as follows:

- The duration of the limited warranty for terminals with an integrated imager is two years.
- The duration of the limited warranty for touch screens is one year provided that a screen protector is applied and an approved stylus is used for the 12-month duration covered by the warranty.
- The duration of the limited warranty for the HomeBase device, QuadCharger device, Mobile Base device, Mobile Charger, Net Base, and ChargeBase is one year.
- The duration of the limited warranty for batteries is one year.
Use of any battery from a source other than Honeywell may result in damage not covered by the warranty. Batteries returned to Honeywell International Inc. in a reduced state may or may not be replaced under this warranty. Battery life will be greatly increased when following the battery instructions in the Dolphin 9000 Mobile Computer User's Guide.

How to Extend Your Warranty

Honeywell International Inc. offers a variety of service plans on our hardware products. These agreements offer continued coverage for your equipment after the initial warranty expires. For more information, contact your Sales Representative, Customer Account Representative, or Product Service Marketing Manager from Honeywell International Inc., or your Authorized Reseller.



Disclaimer

Honeywell International Inc. (“HII”) reserves the right to make changes in specifications and other information contained in this document without prior notice, and the reader should in all cases consult HII to determine whether any such changes have been made. The information in this publication does not represent a commitment on the part of HII.

HII shall not be liable for technical or editorial errors or omissions contained herein; nor for incidental or consequential damages resulting from the furnishing, performance, or use of this material.

This document contains proprietary information that is protected by copyright. All rights are reserved. No part of this document may be photocopied, reproduced, or translated into another language without the prior written consent of HII.

Web Address: www.honeywellaidc.com

Trademarks

Dolphin, Dolphin RF, HomeBase, Mobile Base, and QuadCharger are trademarks or registered trademarks of Hand Held Products, Inc. or Honeywell International Inc.

Microsoft, Windows, Windows Mobile, Windows CE, Windows NT, Windows 2000, Windows ME, Windows XP, ActiveSync, Outlook, and the Windows logo are trademarks or registered trademarks of Microsoft Corporation.

Other product names mentioned in this manual may be trademarks or registered trademarks of their respective companies and are the property of their respective owners.

Patents

Please refer to the product packaging for a list of patents.

©2008–2009 Honeywell International Inc. All rights reserved.

Honeywell

700 Visions Drive
P.O. Box 208
Skaneateles Falls, NY 13153-0208

