

RECOMMENDED PRINTER SUPPLIES TRANSPORTATION & LOGISTICS



TRANSPORTATION & LOGISTICS CONTENTS

SHIPPING / TRACK & TRACE

| | |
|-----------------------------|---|
| Duratherm II XL Paper | 3 |
| Duratherm II Paper..... | 4 |
| Duratherm Receipt..... | 5 |
| Duratran XL..... | 6 |
| Duratran II Paper..... | 7 |
| RFID Duratran II Paper..... | 8 |

CROSS-DOCKING / RECEIVING

| | |
|-----------------------------|----|
| Duratherm II XL Paper | 9 |
| Duratherm II Paper..... | 9 |
| Duratran XL Paper | 10 |
| Duratran II Paper..... | 10 |

RACK, SHELF, AND BIN LABELING

| | |
|--|----|
| Duratran KS Film Label..... | 11 |
| Duratran Pro Film Label..... | 11 |
| FanTastock Gloss Polyester Film Label..... | 12 |

TOTE / RPC LABELS

| | |
|--|----|
| Duratherm S Film Label | 13 |
| Duratran Pro Film Label | 13 |
| FanTastock Gloss Polyester Film Label..... | 14 |

PICK TICKET / PACKING SLIP

| | |
|-----------------------------------|----|
| Duratherm Receipt..... | 15 |
| Duratherm II 7-mil Paper Tag..... | 16 |

THERMAL TRANSFER RIBBONS

| | |
|---------------------------------------|----|
| ThermaMAX 1000 Wax Ribbons..... | 17 |
| ThermaMAX 2000 Mid-Range Ribbons..... | 17 |
| ThermaMAX 3000 Resin Ribbons..... | 17 |

APPENDIX

| | |
|--|----|
| Direct Thermal vs. Thermal Transfer..... | 18 |
| Replacement Printhead Program..... | 18 |
| Application Briefs..... | 19 |

SHIPPING / TRACK & TRACE

DURATHERM II XL PAPER LABEL

A non-top-coated direct thermal paper that offers high-quality, cost-effective printing with improved printer up-time due to more labels per roll. This material is recommended for most general-use applications where exposure to chemicals and moisture is not anticipated. Employs a permanent acrylic adhesive. No ribbon required.

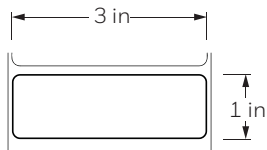

HRLD01901
HRLD01902

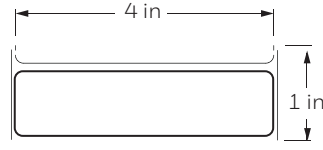

HRLD12811

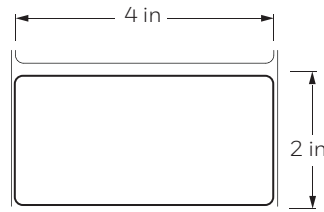

HRLD12809
HRLD12804
HRLD12805
HRLD12803

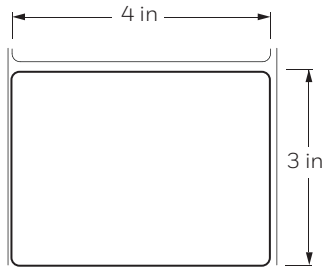

HRLD12802

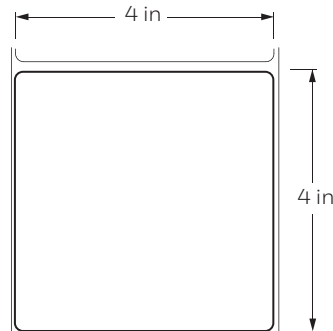

HRLD12800

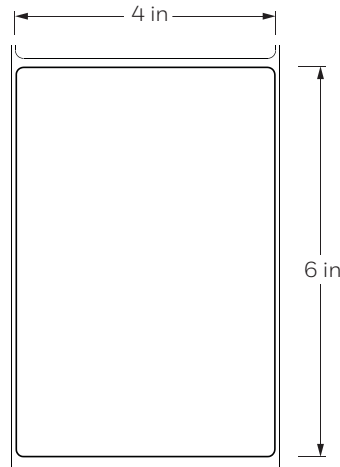

HRLD12808
HRLD12806
HRLD12807
HRLD02803
HRLD12801

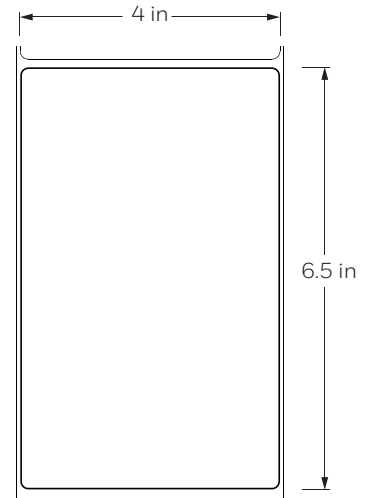

HRLD12810

| Size | ID | OD | Part Number | Printer Configuration | Qty/Roll | Rolls/Ctn | Ctn Weight | Stock/MTO |
|-----------|-------|-------|-------------|-----------------------|----------|-----------|------------|-----------|
| 3" x 1" | 0.75" | 2.6" | HRLD01901 | PB50 | 800 | 32 | 27 lbs | Stock |
| 4" x 2" | 0.75" | 2.6" | HRLD12809 | PB50 | 415 | 32 | 27 lbs | Stock |
| 4" x 6" | 0.75" | 2.6" | HRLD12808 | PB50 | 150 | 32 | 31 lbs | Stock |
| 3" x 1" | 0.75" | 2.25" | HRLD01902 | RP4 | 500 | 32 | 17 lbs | Stock |
| 4" x 2" | 0.75" | 2.25" | HRLD12804 | RP4 | 290 | 32 | 19 lbs | Stock |
| 4" x 6" | 0.75" | 2.25" | HRLD12806 | RP4 | 100 | 32 | 21 lbs | Stock |
| 4" x 2" | 1" | 5" | HRLD12805 | Desktop | 1,750 | 4 | 25 lbs | Stock |
| 4" x 6" | 1" | 5" | HRLD12807 | Desktop | 600 | 4 | 18 lbs | Stock |
| 4" x 1" | 3" | 8" | HRLD12811 | Industrial | 8,250 | 4 | 24 lbs | Stock |
| 4" x 2" | 3" | 8" | HRLD12803 | Industrial | 4,400 | 4 | 19 lbs | Stock |
| 4" x 3" | 3" | 8" | HRLD12802 | Industrial | 3,000 | 4 | 24 lbs | Stock |
| 4" x 4" | 3" | 8" | HRLD12800 | Industrial | 2,200 | 4 | 25 lbs | Stock |
| 4" x 6" | 3" | 8" | HRLD02803 | Industrial | 1,500 | 4 | 36 lbs | Stock |
| 4" x 6.5" | 3" | 8" | HRLD12810 | Industrial | 1,400 | 4 | 24 lbs | Stock |
| 4" x 6" | 3" | 8" | HRLD12801 | MP Compact | 320 | 4 | 24 lbs | Stock |

SHIPPING / TRACK & TRACE

DURATHERM II PAPER LABEL

Duratherm II is a non top-coated direct thermal paper that offers high quality, cost-effective printing. This material is recommended for most general-use applications where exposure to chemicals and moisture is not anticipated.

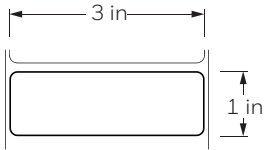

E01383

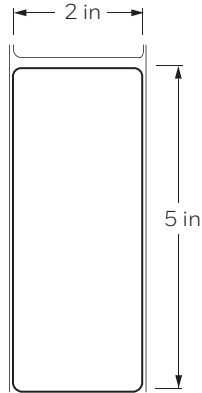

E23470

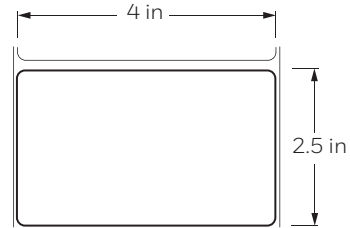

E25735

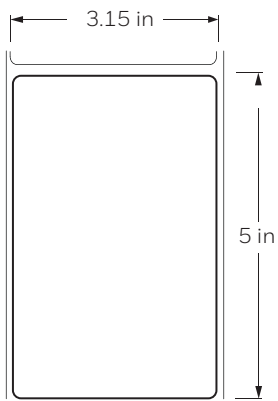

E01384

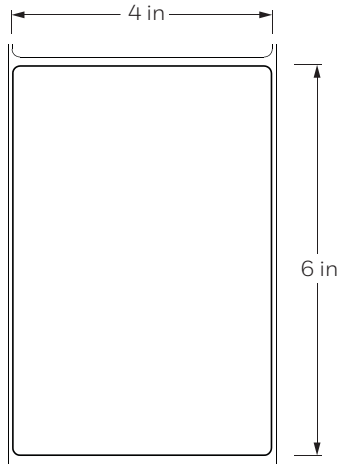

E25726
047164

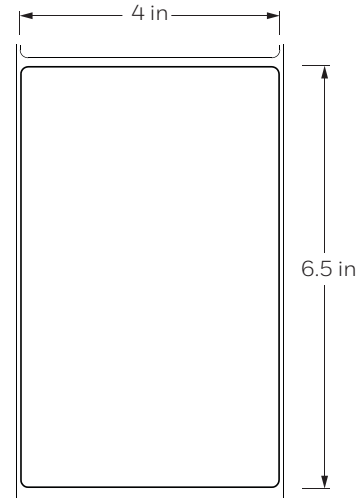

047165

| Size | ID | OD | Part Number | Printer Configuration | Qty/Roll | Rolls/Ctn | Ctn Weight | Stock/MTO |
|------------|----|----|-------------|-----------------------|----------|-----------|------------|-----------|
| 4" x 6" | 1" | 5" | E25726 | Desktop | 496 | 8 | 23 lbs | Stock |
| 2" x 5" | 3" | 8" | E23470 | Industrial | 1,170 | 8 | 23 lbs | Stock |
| 3" x 1" | 3" | 8" | E01383 | Industrial | 5,333 | 4 | 17 lbs | Stock |
| 3.15" x 5" | 3" | 8" | E01384 | Industrial | 1,170 | 4 | 18 lbs | Stock |
| 4" x 2.5" | 3" | 8" | E25735 | Industrial | 2,285 | 4 | 24 lbs | Stock |
| 4" x 6" | 3" | 8" | 047164 | Industrial | 1,000 | 4 | 23 lbs | Stock |
| 4" x 6.5" | 3" | 8" | 047165 | Industrial | 900 | 4 | 23 lbs | Stock |

SHIPPING / TRACK & TRACE

DURATHERM STANDARD RECEIPT

A cost-effective, uncoated direct thermal receipt well suited for most general purpose applications where exposure to water and chemicals is not anticipated. All part numbers are continuous.

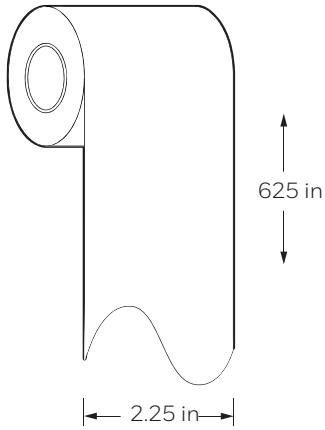

E24788

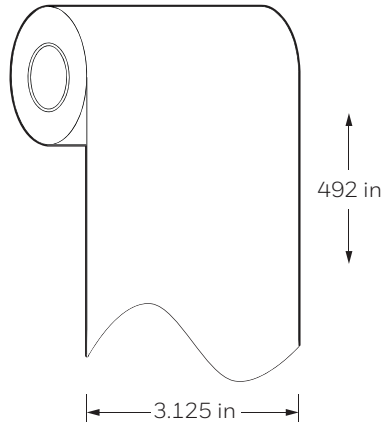

E24789

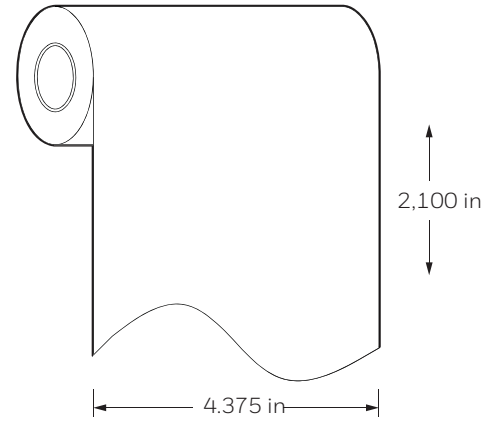

E27145

| Size | ID | OD | Part Number | Printer Configuration | Rolls/Ctn | Ctn Weight | Stock/ MTO |
|-----------------|-------|--------|-------------|-----------------------|-----------|------------|------------|
| 2.25 x 612" | 0.4" | 1.05" | E24788 | PB22, PB32 | 50 | 6 lbs | Stock |
| 3.125" x 492" | 0.4" | 1.375" | E24789 | PB32, PB51 | 50 | 7 lbs | Stock |
| 4.375" x 2,100" | 0.75" | 2.6" | E27145 | PB50, PB51 | 50 | 39 lbs | Stock |

DURATHERM STANDARD PLUS RECEIPT

A cost-effective, uncoated direct thermal receipt well suited for most general purpose applications where exposure to water and chemicals is not anticipated. Requires less energy to image as compared to Duratherm Standard Receipt. All part numbers are continuous.

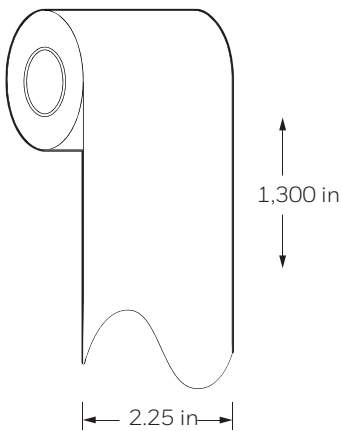

E24619

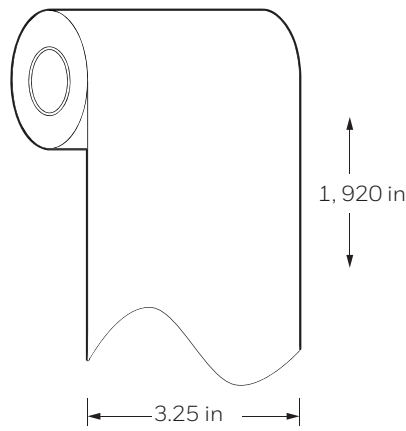

E24631

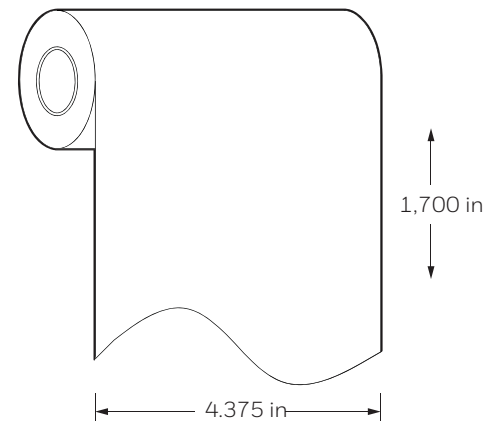

E22977-32

| Size | ID | OD | Part Number | Printer Configuration | Rolls/Ctn | Ctn Weight | Stock/ MTO |
|-----------------|-------|-------|-------------|-----------------------|-----------|------------|------------|
| 2.25 x 1,300" | 0.75" | 2.25" | E24619 | RP2, RP4 | 50 | 14 lbs | Stock |
| 3.25" x 1,920" | 0.75" | 2.25" | E24631 | RP2, RP4 | 50 | 16 lbs | Stock |
| 4.375" x 1,700" | 0.75" | 2.6" | E22977-32 | PB50, PB51 | 32 | 21 lbs | Stock |

SHIPPING / TRACK & TRACE

DURATRAN XL PAPER LABEL

A premium top-coated, ultra-smooth thermal transfer paper laminate employing a thinner, higher-density liner that enables longer roll length. Permanent acrylic adhesive. This product is recommended where moderate abrasion, heat or sunlight are present. Recommended Ribbons: TMX1000 Series and TMX2000 Series. Two Duratran XL rolls per one 18,000" ribbon.

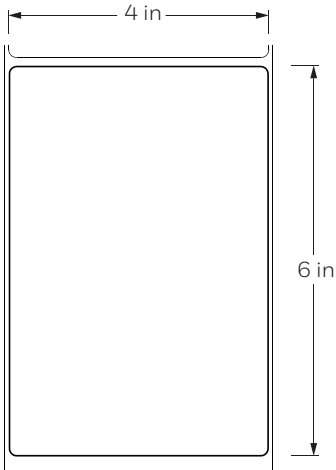

E28816



| Size | ID | OD | Part Number | Printer Configuration | Qty/Roll | Rolls/Ctn | Ctn Weight | Stock/MTO | Desktop 1/2" Ribbon | Desktop 1" Ribbon | Industrial Ribbon |
|---------|----|----|-------------|-----------------------|----------|-----------|------------|-----------|---------------------|-------------------|-------------------|
| 4" x 6" | 3" | 8" | E28816 | Industrial | 1,500 | 4 | 26 lbs | Stock | n/a | n/a | 11234118 |

SHIPPING / TRACK & TRACE

DURATRAN II PAPER LABEL

Duratran II is a top-coated thermal transfer paper that demonstrates excellent print quality with the TMX1500 ribbons. This product is recommended where moderate abrasion, heat or sunlight are present.

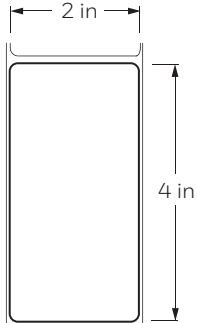

E25879

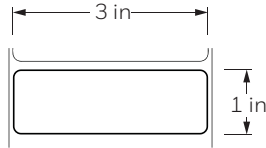

E06172

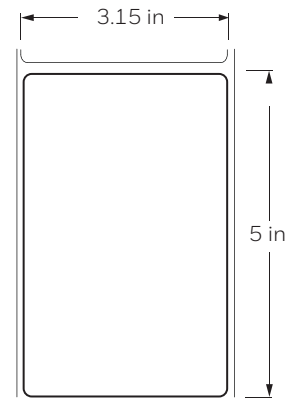

E06173

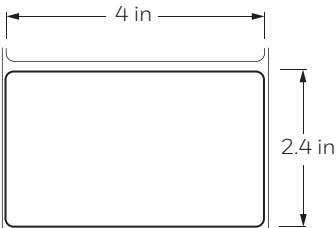

E06174

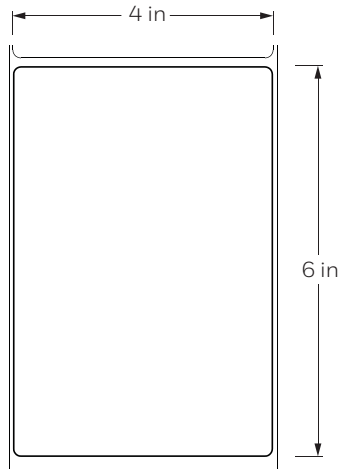

E15527
E06175

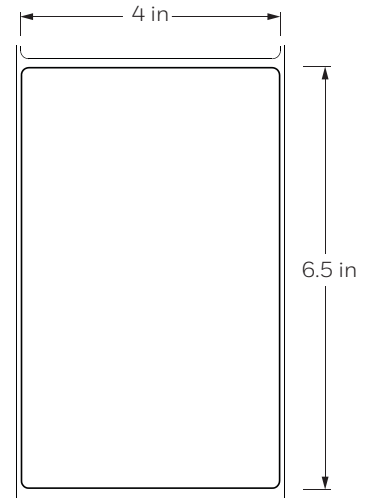

E06176

| Size | ID | OD | Part Number | Printer Configuration | Qty/Roll | Rolls/Ctn | Ctn Weight | Stock/MTO | Desktop 1/2" Ribbon | Desktop 1" Ribbon | Industrial Ribbon |
|-----------|----|----|-------------|-----------------------|----------|-----------|------------|-----------|---------------------|-------------------|-------------------|
| 4" x 6" | 1" | 5" | E15527 | Desktop | 496 | 8 | 22 lbs | Stock | 11044304 | 11234012 | n/a |
| 2" x 4" | 3" | 8" | E25879 | Industrial | 1,450 | 8 | 23 lbs | Stock | n/a | n/a | 11232018 |
| 3" x 1" | 3" | 8" | E06172 | Industrial | 5,500 | 4 | 16 lbs | Stock | n/a | n/a | 11233018 |
| 3.15"x5" | 3" | 8" | E06173 | Industrial | 1,170 | 4 | 18 lbs | Stock | n/a | n/a | 11234118 |
| 4" x 2.4" | 3" | 8" | E06174 | Industrial | 2,400 | 4 | 22 lbs | Stock | n/a | n/a | 11234118 |
| 4" x 6" | 3" | 8" | E06175 | Industrial | 1,000 | 4 | 22 lbs | Stock | n/a | n/a | 11234118 |
| 4" x 6.5" | 3" | 8" | E06176 | Industrial | 900 | 4 | 22 lbs | Stock | n/a | n/a | 11234118 |

SHIPPING / TRACK & TRACE

DURATRAN II RFID PAPER LABEL

A premium top-coated, ultra-smooth thermal transfer paper that demonstrates excellent print quality. Permanent acrylic adhesive. This product is recommended where moderate abrasion, heat or sunlight are present. Recommended Ribbons: TMX1000 Series and TMX2000 Series.

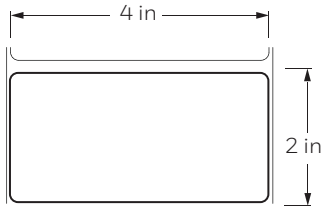

ILR00154
ILR00254
ILR00258

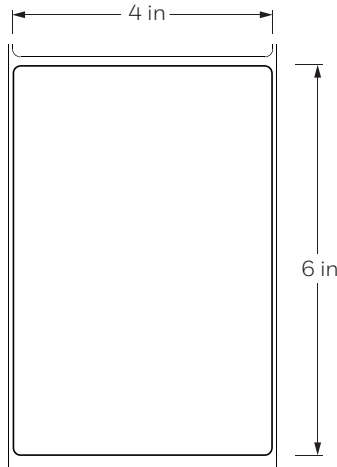

ILR00146
ILR00255
ILR00259
HRRT12800

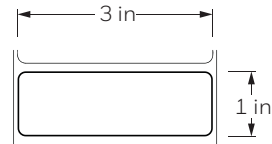

ILR00270

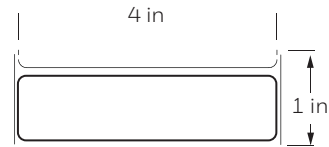

ILR00272



| Size | ID | OD | Part Number | Printer Configuration | Qty/Roll | Rolls/Ctn | Ctn Weight | Stock/MTO | Desktop 1/2" Ribbon | Desktop 1" Ribbon | Industrial Ribbon |
|---------|----|----|-------------|-----------------------|----------|-----------|------------|-----------|---------------------|-------------------|-------------------|
| 3" x 1" | 1" | 5" | ILR00270 | PC43t | 1,004 | 4 | 13 lbs | MTO | 11043304 | 11233011 | n/a |
| 4" x 1" | 1" | 5" | ILR00272 | PC43t | 1,004 | 4 | 13 lbs | MTO | 11044304 | 11234012 | n/a |
| 4" x 2" | 1" | 5" | ILR00258 | PC43t | 775 | 4 | 13 lbs | Stock | 11044304 | 11234012 | n/a |
| 4" x 6" | 1" | 5" | ILR00259 | PC43t | 269 | 4 | 13 lbs | Stock | 11044304 | 11234012 | n/a |
| 4" x 2" | 3" | 8" | ILR00154 | PM4i | 1,411 | 2 | 15 lbs | Stock | n/a | n/a | 11234118 |
| 4" x 2" | 3" | 8" | ILR00254 | PD43, PM43 | 1,411 | 2 | 15 lbs | Stock | n/a | n/a | 11234118 |
| 4" x 6" | 3" | 8" | ILR00146 | PM4i | 489 | 4 | 15 lbs | Stock | n/a | n/a | 11234118 |
| 4" x 6" | 3" | 8" | ILR00255 | PD43, PM43 | 489 | 4 | 15 lbs | Stock | n/a | n/a | 11234118 |
| 4" x 6" | 3" | 8" | HRRT12800 | H-Class, I-Class | 750 | 2 | 23 lbs | Stock | n/a | n/a | 11234118 |

CROSS-DOCKING / RECEIVING

DURATHERM II XL PAPER LABEL

A non-top-coated direct thermal paper that offers high-quality, cost-effective printing with improved printer up-time due to more labels per roll. This material is recommended for most general-use applications where exposure to chemicals and moisture is not anticipated. Employs a permanent acrylic adhesive. No ribbon required.

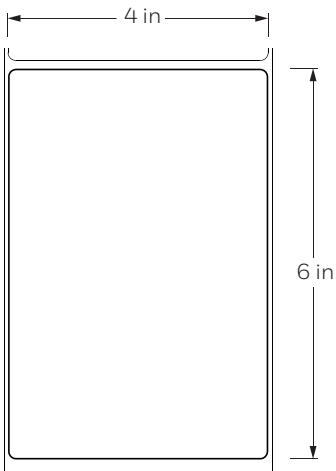

HRLD12808 HRLD12807
HRLD12806 HRLD02803

| Size | ID | OD | Part Number | Printer Configuration | Qty/Roll | Rolls/Ctn | Ctn Weight | Stock/MTO |
|---------|-------|-------|-------------|-----------------------|----------|-----------|------------|-----------|
| 4" x 6" | 0.75" | 2.6" | HRLD12808 | RL4, PB50 | 150 | 32 | 31 lbs | Stock |
| 4" x 6" | 0.75" | 2.25" | HRLD12806 | RP4 | 100 | 32 | 21 lbs | Stock |
| 4" x 6" | 1" | 5" | HRLD12807 | Desktop | 600 | 4 | 18 lbs | Stock |
| 4" x 6" | 3" | 8" | HRLD02803 | Industrial | 1,500 | 4 | 36 lbs | Stock |

DURATHERM II PAPER LABEL

Duratherm II is a non top-coated direct thermal paper that offers high quality, cost-effective printing. This material is recommended for most general-use applications where exposure to chemicals and moisture is not anticipated.

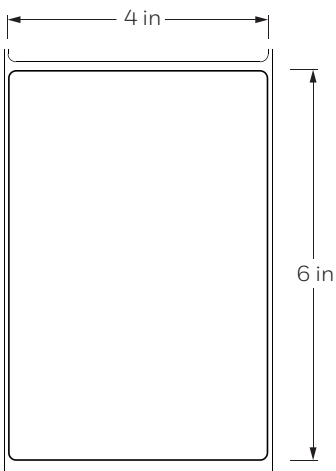

E21016
047164

| Size | ID | OD | Part Number | Printer Configuration | Qty/Roll | Rolls/Ctn | Ctn Weight | Stock/MTO |
|---------|-------|------|-------------|-----------------------|----------|-----------|------------|-----------|
| 4" x 6" | 0.75" | 2.6" | E21016 | RL4, PB50 | 117 | 16 | 12 lbs | Stock |
| 4" x 6" | 3" | 8" | 047164 | Industrial | 1,000 | 4 | 23 lbs | Stock |

CROSS-DOCKING / RECEIVING

DURATRAN XL PAPER LABEL

A premium top-coated, ultra-smooth thermal transfer paper laminate employing a thinner, higher-density liner that enables longer roll length. Permanent acrylic adhesive. This product is recommended where moderate abrasion, heat or sunlight are present. Recommended Ribbons: TMX1000 Series and TMX2000 Series.

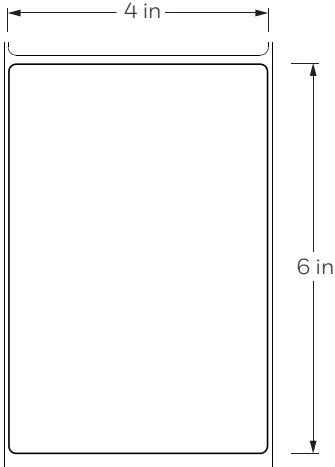

E28816

| Size | ID | OD | Part Number | Printer Configuration | Qty/Roll | Rolls/Ctn | Ctn Weight | Stock/ MTO | Desktop 1/2" Ribbon | Desktop 1" Ribbon | Industrial Ribbon |
|---------|----|----|-------------|-----------------------|----------|-----------|------------|------------|---------------------|-------------------|-------------------|
| 4" x 6" | 3" | 8" | E28816 | Industrial | 1,500 | 4 | 26 lbs | Stock | n/a | n/a | 11234118 |

DURATRAN II PAPER LABEL

Duratran II is a top-coated thermal transfer paper that demonstrates excellent print quality with the TMX1000 Series ribbons. This product is recommended where moderate abrasion, heat or sunlight are present.

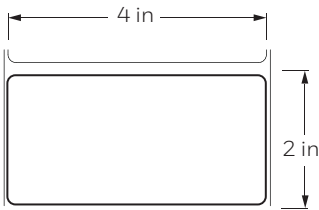

E07516

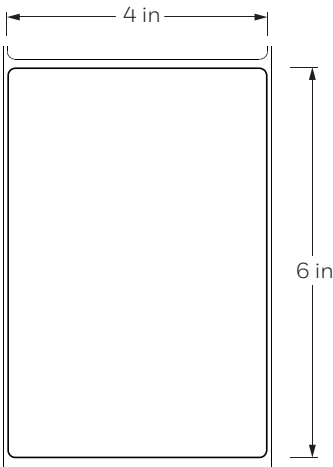

E06175

| Size | ID | OD | Part Number | Printer Configuration | Qty/Roll | Rolls/Ctn | Ctn Weight | Stock/ MTO | Desktop 1/2" Ribbon | Desktop 1" Ribbon | Industrial Ribbon |
|---------|----|----|-------------|-----------------------|----------|-----------|------------|------------|---------------------|-------------------|-------------------|
| 4" x 2" | 3" | 8" | E07516 | Industrial | 2,900 | 4 | 22 lbs | Stock | n/a | n/a | 11234118 |
| 4" x 6" | 3" | 8" | E06175 | Industrial | 1,000 | 4 | 22 lbs | Stock | n/a | n/a | 11234118 |

RACK, SHELF, AND BIN LABELING

DURATRAN KS SYNTHETIC PAPER LABEL

A matte white, 3-mil polypropylene thermal transfer label with good strength, durability, moisture and chemical resistance. Recommended for up to six months of outdoor exposure. Permanent acrylic adhesive. Recommended Ribbons: TMX1000 Series, TMX2000 Series, and TMX3000 Series.

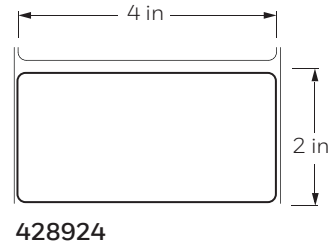
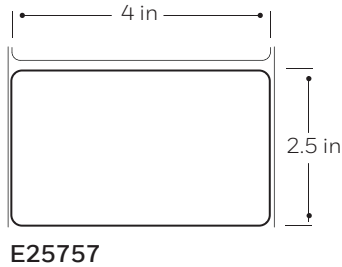
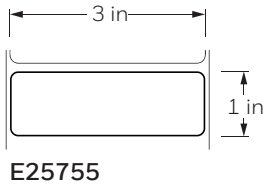

| Size | ID | OD | Part Number | Printer Configuration | Qty/Roll | Rolls/Ctn | Ctn Weight | Stock/ MTO | Desktop 1/2" Ribbon | Desktop 1" Ribbon | Industrial Ribbon |
|-----------|----|----|-------------|-----------------------|----------|-----------|------------|------------|---------------------|-------------------|-------------------|
| 3" x 1" | 1" | 5" | E25755 | Desktop | 2,702 | 8 | 17 lbs | MTO | 11043304 | 11233011 | n/a |
| 4" x 2.5" | 1" | 5" | E25757 | Desktop | 1,158 | 8 | 17 lbs | MTO | 11044304 | 11234012 | n/a |
| 4" x 2" | 3" | 8" | 428924 | Industrial | 2,500 | 4 | 25 lbs | Stock | n/a | n/a | 11234118 |

DURATRAN PRO FILM LABEL

A durable, high-quality polyolefin thermal transfer label. Exhibits good tear resistance and moisture resistance, as well as moderate temperature and chemical resistance. Recommended for one year of outdoor exposure; compatible with self-strip applications in appropriate printers. Recommended Ribbons: TMX1000 Series and TMX2000 Series.

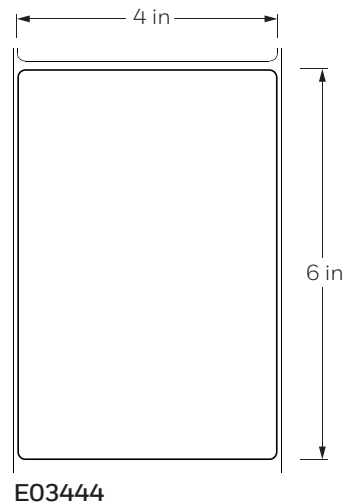
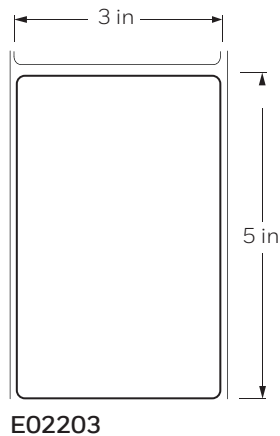
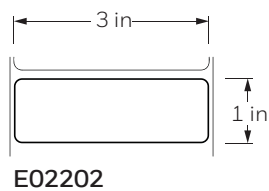

| Size | ID | OD | Part Number | Printer Configuration | Qty/Roll | Rolls/Ctn | Ctn Weight | Stock/ MTO | Desktop 1/2" Ribbon | Desktop 1" Ribbon | Industrial Ribbon |
|---------|----|----|-------------|-----------------------|----------|-----------|------------|------------|---------------------|-------------------|-------------------|
| 3" x 1" | 3" | 8" | E02202 | Industrial | 4,888 | 8 | 38 lbs | Stock | n/a | n/a | 12033118 |
| 3" x 5" | 3" | 8" | E02203 | Industrial | 1,073 | 8 | 40 lbs | Stock | n/a | n/a | 12033118 |
| 4" x 6" | 3" | 8" | E03444 | Industrial | 897 | 4 | 27 lbs | Stock | n/a | n/a | 12234118 |

RACK, SHELF, AND BIN LABELING

FANTASTOCK 1 GLOSS POLYESTER FILM LABEL

A high-gloss, top-coated polyester label with exceptional print quality. Excellent tear, smear and abrasion resistance; highly moisture and heat resistant. Aggressive acrylic adhesive. Product is UL- and cUL-recognized when printed with select ThermaMAX™ 3000 Series ribbons. Recommended Ribbons: TMX3000 Series.

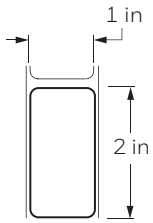

E23067

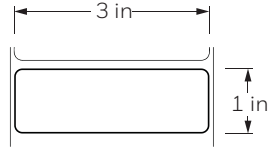

E23068

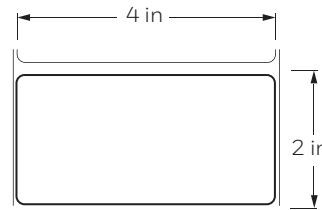

E25747
E23222



| Size | ID | OD | Part Number | Printer Configuration | Qty/Roll | Rolls/Ctn | Ctn Weight | Stock/MTO | Desktop 1/2" Ribbon | Desktop 1" Ribbon | Industrial Ribbon |
|---------|----|----|-------------|-----------------------|----------|-----------|------------|-----------|---------------------|-------------------|-------------------|
| 4" x 2" | 1" | 5" | E25747 | Desktop | 1,430 | 4 | 14 lbs | Stock | 13044304 | 13634012 | n/a |
| 1" x 2" | 3" | 8" | E23067 | Industrial | 2,823 | 4 | 7 lbs | Stock | n/a | n/a | 13632018 |
| 3" x 1" | 3" | 8" | E23068 | Industrial | 5,333 | 4 | 20 lbs | Stock | n/a | n/a | 13633018 |
| 4" x 2" | 3" | 8" | E23222 | Industrial | 2,823 | 4 | 53 lbs | Stock | n/a | n/a | 13634118 |



TOTE / RPC LABELS

DURATHERM S FILM LABEL

A top-coated direct thermal film for superior moisture resistance and print quality. No ribbon required.

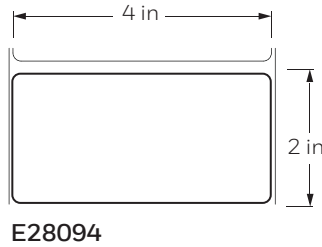
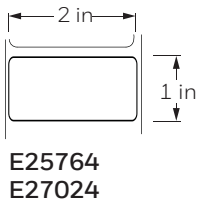

| Size | ID | OD | Part Number | Printer Configuration | Qty/Roll | Rolls/Ctn | Ctn Weight | Stock/ MTO |
|---------|-------|-------|-------------|-----------------------|----------|-----------|------------|------------|
| 2" x 1" | 0.75" | 2.25" | E25764 | RL4, PB50 | 506 | 32 | 9 lbs | Stock |
| 4" x 2" | 3" | 8" | E28094 | Industrial | 2,823 | 4 | 23 lbs | MTO |
| 2" x 1" | 1" | 5" | E27024 | Desktop | 2,702 | 16 | 22 lbs | MTO |

DURATRAN PRO FILM LABEL

A durable, high-quality polyolefin thermal transfer label. Exhibits good tear resistance and moisture resistance, as well as moderate temperature and chemical resistance. Recommended for one year of outdoor exposure; compatible with self-strip applications in appropriate printers. Recommended Ribbons: TMX1000 Series and TMX2000 Series.

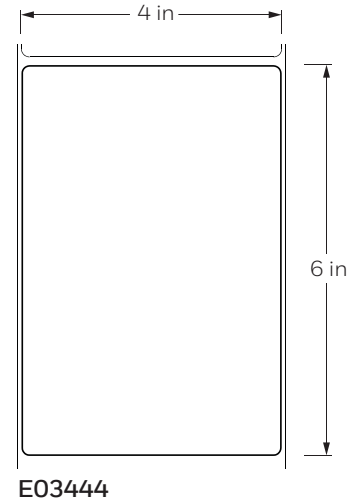
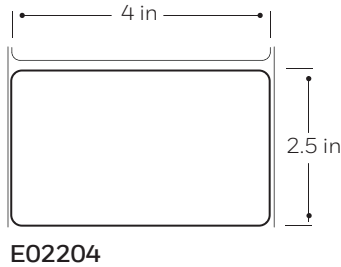
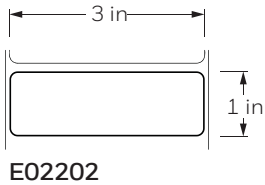

| Size | ID | OD | Part Number | Printer Configuration | Qty/Roll | Rolls/Ctn | Ctn Weight | Stock/ MTO | Desktop 1/2" Ribbon | Desktop 1" Ribbon | Industrial Ribbon |
|-----------|----|----|-------------|-----------------------|----------|-----------|------------|------------|---------------------|-------------------|-------------------|
| 3" x 1" | 3" | 8" | E02202 | Industrial | 4,888 | 8 | 38 lbs | Stock | n/a | n/a | 12033118 |
| 4" x 2.5" | 3" | 8" | E02204 | Industrial | 2,095 | 4 | 27 lbs | Stock | n/a | n/a | 12234118 |
| 4" x 6" | 3" | 8" | E03444 | Industrial | 897 | 4 | 27 lbs | Stock | n/a | n/a | 12234118 |

TOTE / RPC LABELS

FANTASTOCK 1 GLOSS POLYESTER FILM LABEL

A high-gloss, top-coated polyester label with exceptional print quality. Excellent tear, smear and abrasion resistance; highly moisture and heat resistant. Aggressive acrylic adhesive. Product is UL- and cUL-recognized when printed with select ThermaMAX™ 3000 series ribbons. Recommended Ribbons: TMX3000 Series.

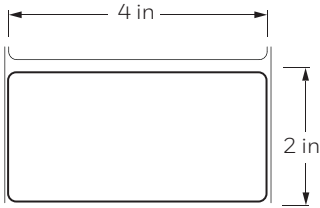

E23222
E25747

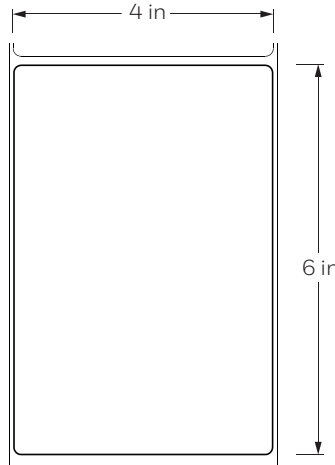

E25733

| Size | ID | OD | Part Number | Printer Configuration | Qty/Roll | Rolls/Ctn | Ctn Weight | Stock/ MTO | Desktop 1/2" Ribbon | Desktop 1" Ribbon | Industrial Ribbon |
|---------|----|----|-------------|-----------------------|----------|-----------|------------|------------|---------------------|-------------------|-------------------|
| 4" x 2" | 1" | 5" | E25747 | Desktop | 1,430 | 4 | 14 lbs | Stock | 13044304 | 13634012 | n/a |
| 4" x 2" | 3" | 8" | E23222 | Industrial | 2,823 | 4 | 53 lbs | Stock | n/a | n/a | 13634118 |
| 4" x 6" | 3" | 8" | E25733 | Industrial | 979 | 4 | 27 lbs | Stock | n/a | n/a | 13634118 |



PICK TICKET / PACKING SLIP

DURATHERM STANDARD RECEIPT

A cost-effective, uncoated direct thermal receipt well suited for most general purpose applications where exposure to water and chemicals is not anticipated. All part numbers are continuous.

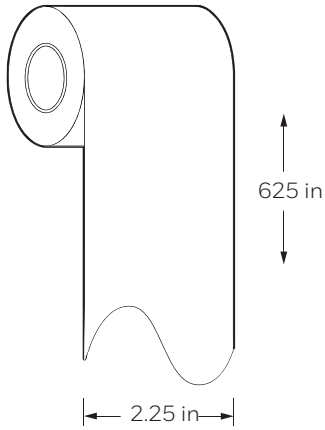

E24788

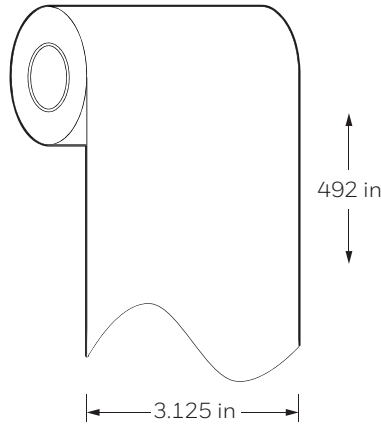

E24789

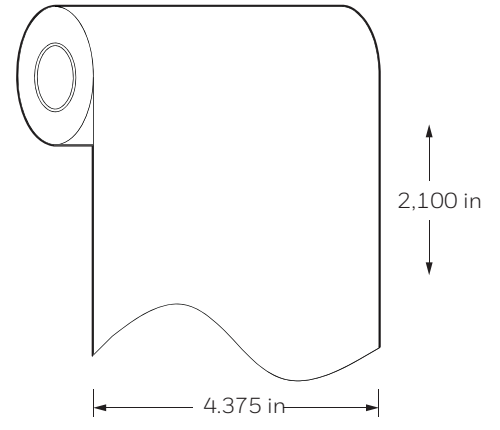

E27145

| Size | ID | OD | Part Number | Printer Configuration | Rolls/Ctn | Ctn Weight | Stock/ MTO |
|-----------------|-------|--------|-------------|-----------------------|-----------|------------|------------|
| 2.25 x 612" | 0.4" | 1.05" | E24788 | PB22, PB32 | 50 | 6 lbs | Stock |
| 3.125" x 492" | 0.4" | 1.375" | E24789 | PB32, PB51 | 50 | 7 lbs | Stock |
| 4.375" x 2,100" | 0.75" | 2.6" | E27145 | PB50, PB51 | 50 | 39 lbs | Stock |

DURATHERM STANDARD PLUS RECEIPT

A cost-effective, uncoated direct thermal receipt well suited for most general purpose applications where exposure to water and chemicals is not anticipated. Requires less energy to image as compared to Duratherm Standard Receipt. All part numbers are continuous.

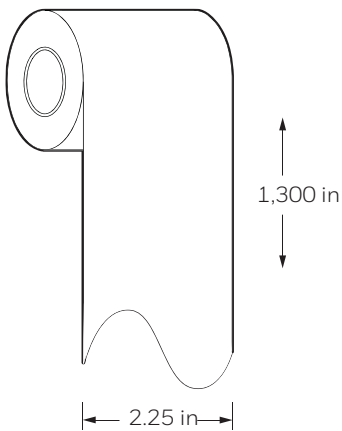

E24619

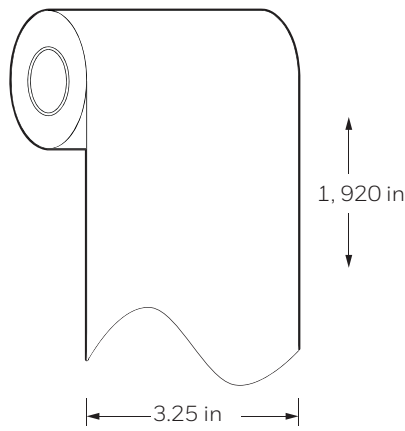

E24631

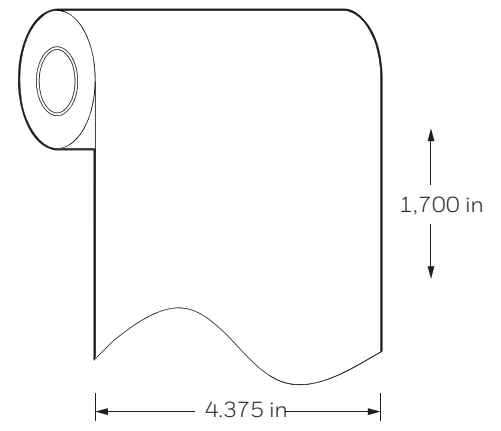

E22977-32

| Size | ID | OD | Part Number | Printer Configuration | Rolls/Ctn | Ctn Weight | Stock/ MTO |
|-----------------|-------|-------|-------------|-----------------------|-----------|------------|------------|
| 2.25 x 1,300" | 0.75" | 2.25" | E24619 | RP2, RP4 | 50 | 14 lbs | Stock |
| 3.25" x 1,920" | 0.75" | 2.25" | E24631 | RP2, RP4 | 50 | 16 lbs | Stock |
| 4.375" x 1,700" | 0.75" | 2.6" | E22977-32 | PB50, PB51 | 32 | 21 lbs | Stock |

PICK TICKET / PACKING SLIP

DURATHERM II 7-MIL PAPER TAG

Duratherm II Tag is a 7-mil non top-coated thermal paper that offers high quality, cost-effective printing. This material is recommended for most general-use applications where exposure to chemicals and moisture is not anticipated. No ribbon required.

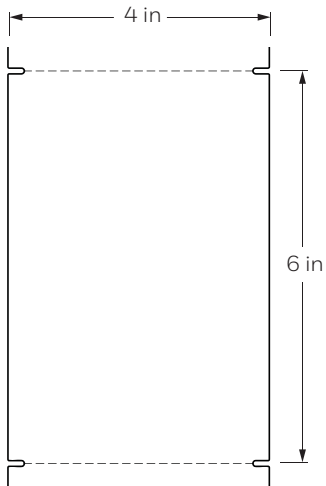

E04633

| Size | ID | OD | Part Number | Printer Configuration | Qty/Roll | Rolls/Ctn | Ctn Weight | Stock/MTO |
|---------|----|----|-------------|-----------------------|----------|-----------|------------|-----------|
| 4" x 6" | 3" | 8" | E04633 | Industrial | 1,000 | 4 | 25 lbs | Stock |

APPENDIX

DIRECT THERMAL VS. THERMAL TRANSFER

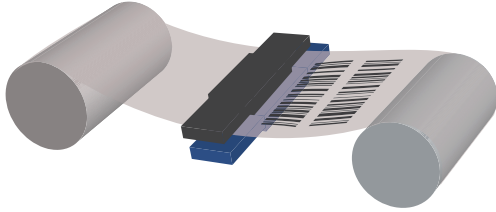

DIRECT THERMAL EXPLAINED

Direct Thermal uses a transparent heat-sensitive coating applied to its surface to image text and bar codes. When the heat from the print head contacts the coating, it initiates a chemical reaction that turns the coating black.

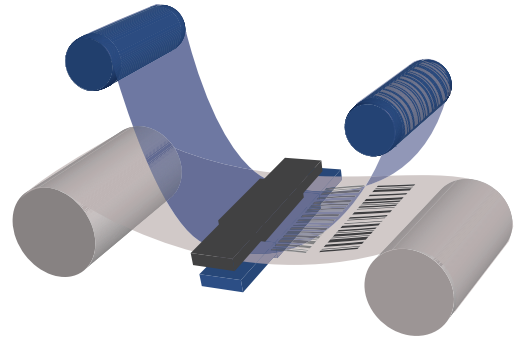

THERMAL TRANSFER EXPLAINED

Thermal Transfer uses a ribbon to image the text and bar codes on a variety of materials, both paper and film. When the ribbon is passed beneath the print head, the heat softens the ribbon ink while in contact with the label or tag, resulting in the transfer of the ink to the surface of the label or tag. There are three general classes of ribbons that are used in thermal printers: Wax, Mid-range, and Resin.

Wax ribbons are the most commonly used class and are mostly targeted to print paper labels and tags that will be exposed to relatively benign environments. Wax ribbons are also used to print on film labels and tags in some applications.

Mid-range ribbons are a hybrid design where resin is mixed with the wax to produce ribbons with durability properties that fall somewhere between the wax and resin ribbons. Mid-range ribbons are used to print on both paper and film labels and tags.

Resin ribbons are the most durable and are mostly targeted to printing on film labels and tags that will be exposed to extreme environments.

PRINTHEAD REPLACEMENT PROGRAM

The most comprehensive printhead replacement program in the industry:

- Provides no-cost printhead replacement for all Honeywell industrial and desktop printers to customers that exclusively use Honeywell genuine printer supplies.
- Reduces total cost of ownership, speeds up return on investment.
- Applies to all Honeywell printer supplies.
- Available in the Americas and EMEA.

APPENDIX

APPLICATION BRIEFS

Honeywell offers a mix of label, tag, and ribbon products to address the requirements of many specific industry applications. Honeywell has developed many Applications Brief documents that detail the printer supply performance and regulatory requirements for specific applications for a variety of industries. Below you will find a few Application Briefs targeted specifically at the Transportation and Logistics market.

Cold Chain Food Labeling

The cold chain industry faces a standard set of challenges to improve efficiencies, optimize inventory turns, and maintain profitability in a highly competitive environment. However, these are supplemented with increasingly stringent government regulations, the requirement to maintain a highly consistent controlled environment across all four seasons, and the need to document flawless performance when managing sensitive perishable food products such as seafood, meat, dairy, and produce.



SUMMARY

Industry

Products

Region

Typical Applications

Customer Benefits

Industry Need

The cold chain industry faces a standard set of challenges to improve efficiencies, optimize inventory turns, and maintain profitability in a highly competitive environment. However, these are supplemented with increasingly stringent government regulations, the requirement to maintain a highly consistent controlled environment across all four seasons, and the need to document flawless performance when managing sensitive perishable food products such as seafood, meat, dairy, and produce.

Customer Benefits

- Document compliance with government and industry standards.
- Increase product traceability from supplier to customer.
- Improve accuracy in shipping, handling, handling control.
- Full range of product labels and application requirements (e.g., moisture, high humidity).
- High quality, durable labels available for specific climates.
- Superior product performance.
- Superior product performance.
- Superior product performance.



Portable Labeling in the Warehouse of Manufacturing Facility

Bar coding is a critical component in maintaining accuracy and efficiency in a warehouse environment. Shipping, receiving and cross docking, picking and packing, shelf labeling, and tote labeling applications are integral to successful operations. Increasingly, companies are leveraging portable labeling solutions in these applications. By enabling workers to print labels at the point of activity, portable solutions enable a more flexible workflow, increased productivity and fewer errors. Honeywell's integrated portable printer and Duratherm printer supplies deliver a comprehensive array of choices to meet these needs.



SUMMARY

Industry

Products

Region

Typical Applications

Customer Benefits

Industry Need

Bar coding is a critical component in maintaining accuracy and efficiency in a warehouse environment. Shipping, receiving and cross docking, picking and packing, shelf labeling, and tote labeling applications are integral to successful operations. Increasingly, companies are leveraging portable labeling solutions in these applications. By enabling workers to print labels at the point of activity, portable solutions enable a more flexible workflow, increased productivity and fewer errors. Honeywell's integrated portable printer and Duratherm printer supplies deliver a comprehensive array of choices to meet these needs.

Customer Benefits

- Increased productivity and efficiency by printing at the point of activity.
- Full range of product labels and application requirements (e.g., moisture, high humidity).
- Superior product performance.
- Superior product performance.
- Superior product performance.



Portable Admission Ticket Printing

Advances in portable ticket printing have enabled users to overcome these limitations by moving ticketing to the point of activity. Taking transactions to the customer places processing points where they are needed most, increasing throughput and reducing wait times. However, this application is not without its challenges. Key requirements must be met for portable ticketing success; these needs include materials with appropriate durability, look and feel, speedy printing, and rugged, reliable equipment.



SUMMARY

Industry

Products

Region

Typical Applications

Customer Benefits

Industry Need

Advances in portable ticket printing have enabled users to overcome these limitations by moving ticketing to the point of activity. Taking transactions to the customer places processing points where they are needed most, increasing throughput and reducing wait times. However, this application is not without its challenges. Key requirements must be met for portable ticketing success; these needs include materials with appropriate durability, look and feel, speedy printing, and rugged, reliable equipment.

Customer Benefits

- Increased productivity and efficiency by printing at the point of activity.
- Full range of product labels and application requirements (e.g., moisture, high humidity).
- Superior product performance.
- Superior product performance.
- Superior product performance.



For more information

www.honeywellaidc.com

Honeywell Safety and Productivity Solutions

9680 Old Bailes Road
Fort Mill, SC 29707

Honeywell Printer Supplies Customer Service

9290 LeSaint Drive
Fairfield, OH 45014
Phone: (800) 755-5505 opt# 2
Fax: (800) 227-1707
Order and Inquiries:
Media.orders@honeywell.com

