



Serial/Industrial Interface Kit

For PX4ie, PX6ie

Installation Guide

Introduction

The installation guide describes how to physically install the Serial/Industrial Interface Kit for PX4ie and PX6ie printers.

Contents

- One Serial/Industrial interface board fitted with circuits and straps for RS-232 non-isolated.
- One hexagonal spacer
- Two flat cables

The only tools required for the installation are #T10 and #T20 Torx screwdrivers and a small wrench.

Installing the Serial/Industrial Interface Kit



Warning: The installation described in this section must only be performed by an authorized service technician. Honeywell assumes no responsibility for personal injury or damage to the equipment if the installation is performed by an unauthorized person.



Follow standard ESD guidelines to avoid damaging the equipment.



Caution: Before you begin, turn off the printer and disconnect the power cord and communication cables.

Follow the procedure to physically install the Serial/Industrial Interface Kit in the printer.

Note: This procedure applies to both the PX4ie and PX6ie. For simplicity, the PX4ie is depicted in the illustrations.

1. Switch off the power and disconnect the power cord.
2. Disconnect all communication cables.
3. Open the right-hand door.

4. Remove the eight #T10 Torx screws that hold the left-hand cover.

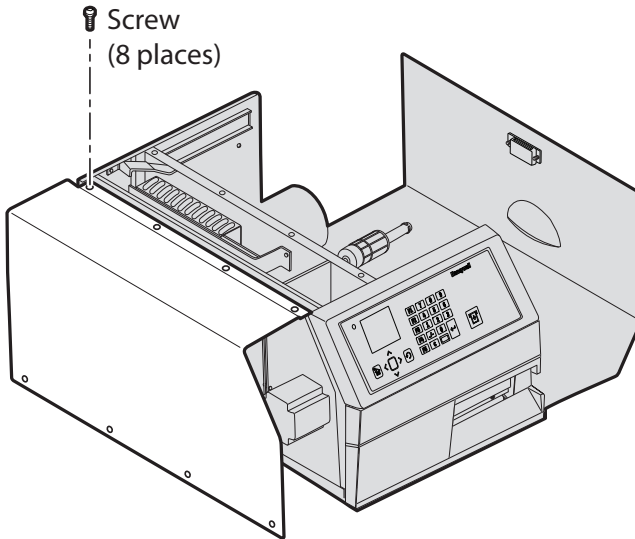

5. Put the cover aside on a soft cloth or similar to avoid scratches.



Warning: The electronics compartment contains high voltage components and wires. Do not open the electronics compartment before the printer is safely disconnect from any AC supply.

6. Remove the one or two cover plates depending on how many interface boards you are going to install. Each plate is held by two #T10 Torx screws. Always start installation at the innermost position.

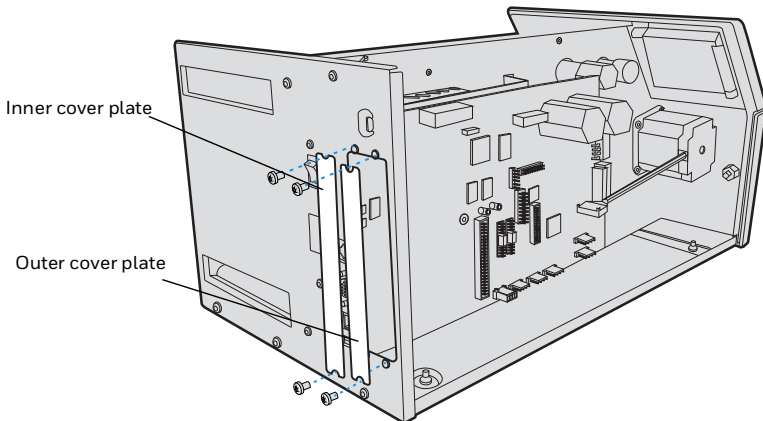

7. Save the cover plate(s) for possible later use. Keep the screws.
8. Remove the #T20 Torx screw fitted on the hexagonal spacer at the center of the CPU board. Keep the screw.
9. If necessary, reconfigure the interface board by fitting or removing circuits and straps according to the descriptions of each board.
10. Attach the flat cable included in the kit to connector on the CPU board.
11. Insert the interface board with the component side facing right, as seen from behind.

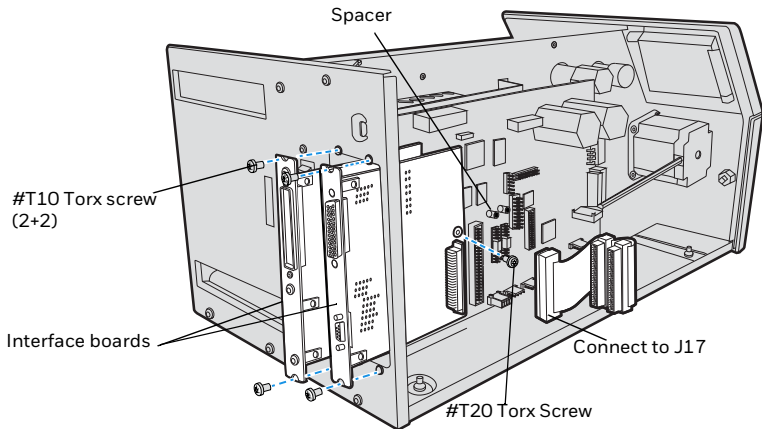

12. Installation of one board: Attach the interface board in the innermost slot in the printer's rear plate using the two screws left over when you removed the original cover plate. Using the #T20 Torx screw you previously removed, attach the interface board to the hexagonal spacer at the center of the CPU board.
13. Installations of two board: first install the inner board, then the outer one. Put the hexagonal spacer included in the kit between the inner and the outer interface board, and finally secure the outer board with the screw.
14. The kit contains two flat cables, one with two connectors for use with a single interface board and one with three connectors for use with double interface boards. Connect the appropriate flat cable to connector P1 on the interface board.

15. The flat cable should run as illustrated.

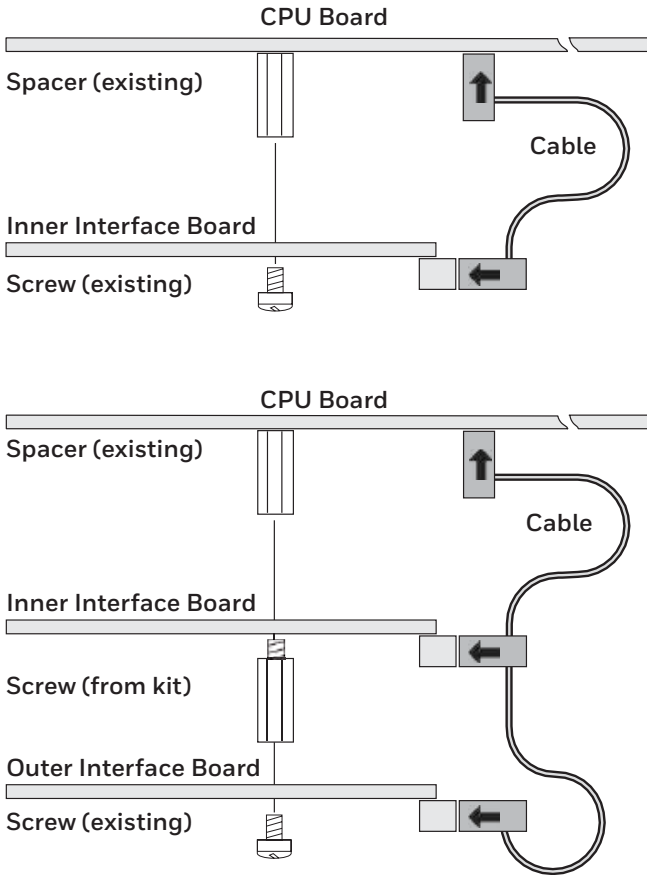

16. Put back the cover over the electronics compartment.

17. Connect the communication cables to the connectors on the printer's rear plate.

18. Connect the power cord and switch on the power.

19. In case the interface provides additional serial communication ports, enter the Setup Mode to set the proper communication parameters for these ports.

Left-hand slot	Ports	Right-hand slot	Ports
Double Serial	uart2: + uart3:	-	-
Double Serial	uart2: + uart3:	Double Serial	uart4: + uart5:
Double Serial	uart2: + uart3:	Serial/Industrial	uart4:
Double Serial	uart2: + uart3:	IEEE1284	centronics:
Serial/Industrial	uart2:	-	-
Serial/Industrial	uart2:	Serial/Industrial	uart3:
Serial/Industrial	uart2:	Double Serial	uart3: + uart4:
Serial/Industrial	uart2:	IEEE1284	centronics:
IEEE1284	centronics:	-	-
IEEE1284	centronics:	Double Serial	uart2: + uart3:
IEEE1284	centronics:	Serial/Industrial	uart2:

Remarks

- The left-hand slot is the slot closest to the center section.
- Always start by fitting an interface board in the left-hand slot.
- RS-485 is only supported by “uart2:”

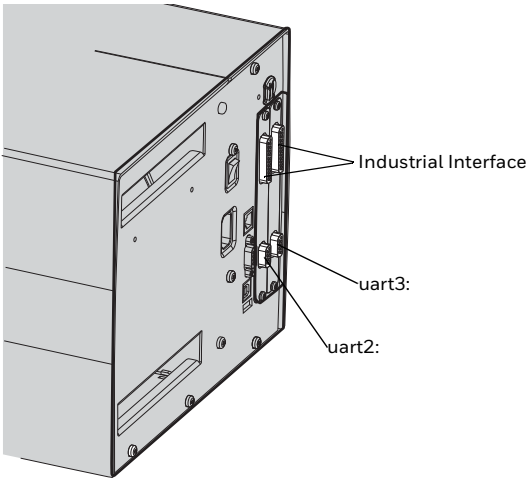

Serial Interface

This chapter describes how to modify the interface board for RS-232 non-isolated (standard), RS-422 isolated/full duplex, or RS-485 isolated/half duplex on the port and explains the configuration of the interface connector.



Caution: When fitting driver circuit and straps before installing the interface board, make sure that the circuit is not fitted upside down (see front end markings in the illustration). Also make sure that the “legs” of the circuit fit into the slots in the socket and are not bent. Take ample precautions to protect the board and circuits from electrostatic discharges.

Install the jumpers and ICs on the board to configure it for the type of serial communication you want to use.

To configure the board as:	Install these jumpers and ICs:
RS-232	<ol style="list-style-type: none">1 Install a jumper on P3 so that the A is in the middle of the jumper.2 Install IC, 360-028-001 (MAX238) on SKT3 with pin 1 located where the arrow points to SKT3 toward the bottom of the board.
RS-422	<ol style="list-style-type: none">1 Install jumpers on P4 and P5.2 Install IC, 360-027-001 (MAX1490), across sockets SKT1 and SKT4 with pin 1 located where the arrow is pointing to SKT1 towards the bottom of the board.
RS-485	<ol style="list-style-type: none">1 Install a jumper on P2.2 (Optionally) Install a jumper on P5 if this printer is going to be connected to the end of the cable.3 Install IC, 360-026-001 (MAX1480), across SKT2 and SKT5 with pin 1 located where the arrow is pointing to SKT2 towards the bottom of the board.

RS-232 Connector Configuration

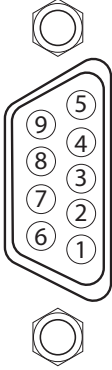
RS-232 Socket as seen from the outside	DB-9 Socket	Signal	Meaning
	1		External +5VDC max 500mA (automatic switch off at overload, short-circuit protected)
	2	TXD	Transmit data
	3	RXD	Receive data
	4	DSR	Data set ready
	5	GND	Ground
	6	DTR	Data terminal ready
	7	CTS	Clear to send
	8	RTS	Request to send
	9	-	Not used

RS-422 Connector Configuration

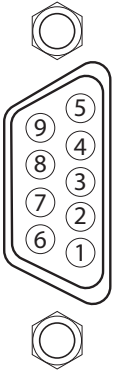
RS-422 Socket as seen from the outside	DB-9 Socket	Signal	Meaning
	1		External +5VDC max 500mA (automatic switch off at overload, short-circuit protected) provided strap is fitted on P3:A which spoils the galvanical isolation
	2	+TXD	+Transmit data
	3	+RXD	+Receive data
	4	-	
	5	GNDE	Ground
	6	-	
	7	-RXD	-Receive data
	8	-TXD	-Transmit data
	9	-	

RS-485 Connector Configuration

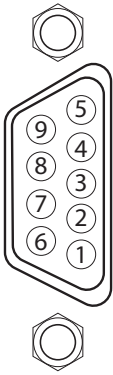
RS-485 Socket as seen from the outside	DB-9 Socket	Signal	Meaning
	1		External +5VDC max 500mA (automatic switch off at overload, short-circuit protected) provided strap is fitted on P3:A which spoils the galvanical isolation
	2	+DATA	
	3	-	
	4	-	
	5	GNDE	Ground
	6	-	
	7	-	
	8	-DATA	
	9	-	

Note: The increased use of LAN networks has made the RS-485 interface somewhat obsolete, because RS-485 requires a special communication protocol and a dedicated wiring system limited to 1,200m (4000ft). We only recommend RS-485 for existing applications and advise the customer to consider a LAN network solution for new applications.

Industrial Interface

This section describes the Industrial Interface, which provides 8 digital IN ports with optocouplers, 8 digital OUT ports with optocouplers, and 4 OUT ports with relays.

The Industrial Interface has no straps or circuits to be fitted or removed. All signals are available on a DB44 pin socket and the various ports are controlled by the Intermec Fingerprint instructions PORTIN and PORTOUT ON/OFF (see Intermec Fingerprint Programmer's Reference Manual).

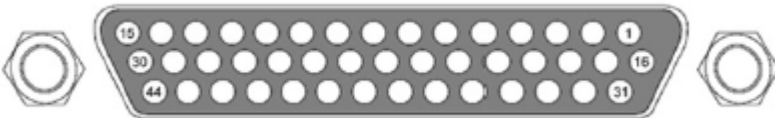

Digital Opto In

The status of the digital IN ports can be read using PORTIN functions. If a current is led through the optocoupler of the port, PORTIN returns the value -1 (true), else it returns the value 0 (false).

Signal	Description	Min.	Typical	Max.
Vin [High]	Input Voltage High	10V	24V	40V
Vin [Low]	Input Voltage Low	-1V	0V	1V

Connector Configuration

Pin	Signal	Description	Fingerprint Ref. No.
10	IN1A	Anode Opto In Channel 1+	101 (301)
40	IN1K	Cathode Opto In Channel 1-	
26	IN2A	Anode Opto In Channel 2+	102 (302)
11	IN2K	Cathode Opto In Channel 2-	
41	IN3A	Anode Opto In Channel 3+	103 (303)
27	IN3K	Cathode Opto In Channel 3-	
12	IN4A	Anode Opto In Channel 4+	104 (304)
42	IN4K	Cathode Opto In Channel 4-	
28	IN5A	Anode Opto In Channel 5+	105 (305)
13	IN5K	Cathode Opto In Channel 5-	
43	IN6A	Anode Opto In Channel 6+	106 (306)
29	IN6K	Cathode Opto In Channel 6-	
14	IN7A	Anode Opto In Channel 7+	107 (307)
44	IN7K	Cathode Opto In Channel 7-	
30	IN8A	Anode Opto In Channel 8+	108 (308)
15	IN8K	Cathode Opto In Channel 8-	

Note: The Fingerprint reference numbers inside the parentheses refer to a second Serial/Industrial interface board.

Simplified schematics of a digital IN port

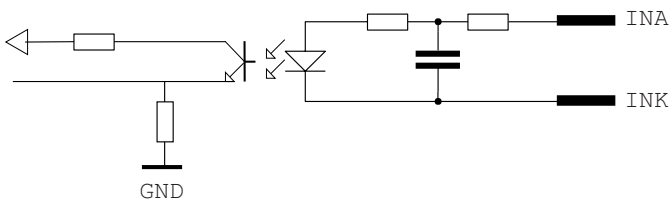

Digital Opto Out

The current to each optocoupler of the digital OUT ports can be turned on and off using PORTOUT ON/OFF statements.

The status of the ports can be read using PORTIN functions. If a current is led through the optocoupler of the port, PORTIN returns the value -1 (true), else it returns the value 0 (false).

Signal	Description	Max.
Vceo	Collector-Emitter breakdown voltage	35V
Veco	Emitter-Collector breakdown voltage	6v
Ic	Collector Current	15mA

Connector Configuration

Pin	Signal	Description	Fingerprint Ref. No.
20	Out1c	Collector Opto Out Channel 1	221 (421)
5	Out1e	Emitter Opto Out Channel 1	
35	Out2c	Collector Opto Out Channel 2	222 (422)
21	Out2e	Emitter Opto Out Channel 2	
6	Out3c	Collector Opto Out Channel 3	223 (423)
36	Out3e	Emitter Opto Out Channel 3	
22	Out4c	Collector Opto Out Channel 4	224 (424)
7	Out4e	Emitter Opto Out Channel 4	
37	Out5c	Collector Opto Out Channel 5	225 (425)
23	Out5e	Emitter Opto Out Channel 5	
8	Out6c	Collector Opto Out Channel 6	226 (426)
38	Out6e	Emitter Opto Out Channel 6	
24	Out7c	Collector Opto Out Channel 7	227 (427)
9	Out7e	Emitter Opto Out Channel 7	
39	Out8c	Collector Opto Out Channel 8	228 (428)
25	Out8e	Emitter Opto Out Channel 8	

Note: The Fingerprint reference number inside the parentheses refer to a second Serial/Industrial interface board.

Simplified Schematics of a digital OUT port

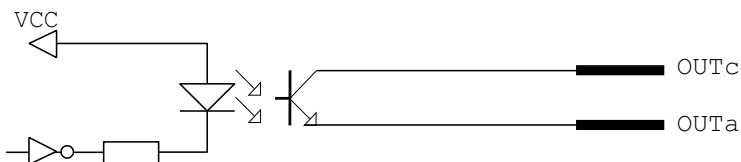

Relay Out

The relays of the OUT ports can be individually activated using PORT-OUT ON/OFF statements.

The status of the ports can be read by means of PORTIN functions. If a relay is activated, PORTIN returns the value -1 (true), else it returns the value 0 (false).

Max AC Load Breaking Capacity

Signal	Description	Max.
I	Current	1A
Psw AC	Switching power	100VA AC
Usw AC	Switching voltage	100V AC

Max DC Load Breaking Capacity

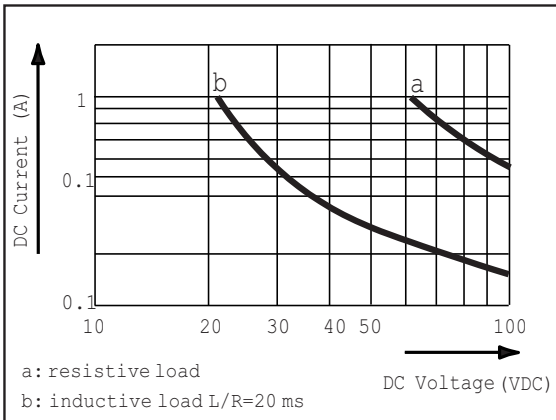

Connector Configuration

Pin	Signal	Description	Fingerprint Ref. No.
16	REL1nc	Relay 1 Normally Closed	201 (401)
1	REL1no	Relay 1 Normally Open	
31	REL1com	Relay 1 Common	
17	REL2nc	Relay 2 Normally Closed	202 (402)
2	REL2no	Relay 2 Normally Open	
32	REL2com	Relay 2 Common	
18	REL3nc	Relay 3 Normally Closed	203 (403)
3	REL3no	Relay 3 Normally Open	
33	REL3com	Relay 3 Common	
19	REL4nc	Relay 4 Normally Closed	204 (404)
4	REL4no	Relay 4 Normally Open	
34	REL4com	Relay 4 Common	

Note: The Fingerprint reference numbers inside the parentheses refer to a second Serial/Industrial interface board.

Simplified schematics of a relay OUT port

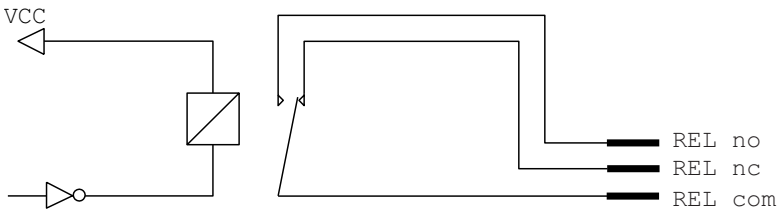

Support

To search our knowledge base for a solution or to log into the Technical Support portal and report a problem, go to www.hsmcontactsupport.com.

Documentation

Product documentation is available at www.honeywellaidc.com.

Limited Warranty

For warranty information, go to www.honeywellaidc.com and click **Resources > Product Warranty**.

Patents

For patent information, see www.hsmpats.com.

Disclaimer

Honeywell International Inc. (“HII”) reserves the right to make changes in specifications and other information contained in this document without prior notice, and the reader should in all cases consult HII to determine whether any such changes have been made. The information in this publication does not represent a commitment on the part of HII.

HII shall not be liable for technical or editorial errors or omissions contained herein; nor for incidental or consequential damages resulting from the furnishing, performance, or use of this material. HII disclaims all responsibility for the selection and use of software and/or hardware to achieve intended results.

This document contains proprietary information that is protected by copyright. All rights are reserved. No part of this document may be photocopied, reproduced, or translated into another language without the prior written consent of HII.

Copyright © 2009-2020 Honeywell International Inc. All rights reserved.